

2011

# Remote monitoring and security of covered bridges in the United States

Ryan Allen Sievers  
*Iowa State University*

Follow this and additional works at: <https://lib.dr.iastate.edu/etd>

 Part of the [Civil Engineering Commons](#)

## Recommended Citation

Sievers, Ryan Allen, "Remote monitoring and security of covered bridges in the United States" (2011). *Graduate Theses and Dissertations*. 12462.  
<https://lib.dr.iastate.edu/etd/12462>

This Thesis is brought to you for free and open access by the Iowa State University Capstones, Theses and Dissertations at Iowa State University Digital Repository. It has been accepted for inclusion in Graduate Theses and Dissertations by an authorized administrator of Iowa State University Digital Repository. For more information, please contact [digirep@iastate.edu](mailto:digirep@iastate.edu).

Remote monitoring and security of covered bridges in the United States

by

Ryan Allen Sievers

A thesis submitted to the graduate faculty  
in partial fulfillment of the requirements for the degree of  
MASTER OF SCIENCE

Major: Civil Engineering (Structural Engineering)

Program of Study Committee:  
Terry J Wipf, Major Professor  
Jennifer Shane  
Vinay Dayal  
Travis K Hosteng

Iowa State University

Ames, Iowa

2012

Copyright © Ryan Allen Sievers, 2012. All Rights Reserved.

## TABLE OF CONTENTS

LIST OF FIGURES .....	iv
LIST OF TABLES .....	vi
ACKNOWLEDGMENTS .....	vii
ABSTRACT.....	viii
CHAPTER 1 INTRODUCTION .....	1
1.1 Overview - Covered Bridge Surveillance Project, Iowa State University .....	1
1.2 Scope of Work .....	2
1.3 Creative Component .....	2
CHAPTER 2 LITERATURE REVIEW .....	4
2.1 Previous Literature with Covered Bridges.....	4
2.2 The Beginning of Covered Bridges in the United States .....	5
2.3 Structural Integrity .....	6
2.4 Targeting Covered Bridges: Arson and Vandalism .....	6
2.5 Importance of Historical Integrity .....	10
CHAPTER 3 PHYSICAL SECURITY OF STRUCTURES .....	12
3.1 Blue Ribbon Panel Workshop on Bridge and Tunnel Security .....	12
CHAPTER 4 COVERED BRIDGE MONITORING SYSTEM: DESIGN .....	15
4.1 Preliminary Decisions .....	15
4.2 Equipment Options .....	17
4.3 Pole Placement.....	36
4.4 Enclosure Selection.....	39
4.5 Power Considerations .....	42
CHAPTER 5 SET-UP.....	48
5.1 Conduit.....	48
5.2 Wiring .....	48
5.3 Attachment Devices .....	50
5.4 Encasements.....	50
5.5 Supplementary Equipment.....	52
CHAPTER 6 TESTING AND MAINTENANCE.....	54
6.1 In-house Testing.....	54
6.2 In-field Testing.....	54
6.3 Maintenance .....	55
CHAPTER 7 CONCLUSION.....	56
7.1 What These Levels of Bridge Security Hope to Accomplish .....	56
7.2 Recommendations .....	56

7.3 Phases of Monitoring or Security System.....	57
7.4 Future Research Needs .....	59
CHAPTER 8 MADISON COUNTY PROJECT .....	61
8.1 History of the Covered Bridges of Madison County .....	61
8.2 Security Equipment Installed.....	62
8.3 Challenges with Each Bridge.....	80
8.4 Testing.....	101
CHAPTER 9 CASE STUDIES.....	105
9.1 Union County Covered Bridges.....	106
9.2 Knecht's Covered Bridge.....	107
9.3 Pomeroy-Academia Covered Bridge .....	108
9.4 Cedar Covered Bridge .....	109
9.5 Illinois Covered Bridges .....	110
APPENDIX A CREATIVE COMPONENT: INSTALLATION OF SECURITY SYSTEM IN MADISON COUNTY .....	112
A.1 Pole Site Selection .....	112
A.2 NEMA Enclosure Selection.....	113
A.3 Install Flame Detectors .....	116
A.4 Install Cameras and Antennas.....	119
A.5 Renewable Energy System.....	121
A.6 Testing of Monitoring Systems.....	130
APPENDIX B DECISION MAKING TOOL .....	134
APPENDIX C NCBPPA BUDGET .....	145
APPENDIX D MADISON PROJECT EQUIPMENT SPECIFICATIONS .....	157
CHAPTER 10 REFERENCES .....	172

## LIST OF FIGURES

Figure 1: Equipment Options.....	16
Figure 2: Flowchart of Equipment Options .....	18
Figure 3: Equipment Selection Tool.....	19
Figure 4: Different Types of Bollards Installed.....	25
Figure 5: Standard K-rail .....	26
Figure 6: Chain Link Fence with Barbed Wire at 45-Degree Angle .....	28
Figure 7: Wind Speed to Power Output Graph for 600 watt Wind Turbine.....	45
Figure 8: AWG Chart for Diameter, Area, and Resistance .....	49
Figure 9: Flame Detector in Covered Bridge without Encasement (top) and With Encasement (Bottom).....	51
Figure 10: 11G Wireless Nano Router.....	65
Figure 11: Dell Optiplex 780 Personal Computer .....	66
Figure 12: Raven XE EV-DO Rev.....	66
Figure 13: Web Based Remote Power Switch.....	67
Figure 14: Power Injector for Optical Camera .....	67
Figure 15: Omega IDR-PR Signal Conditioner.....	68
Figure 16: Omega EIS-2B Microserver.....	69
Figure 17: MDR-60-24 Power Supply.....	69
Figure 18: MDR-10-5 Power Supply.....	70
Figure 19: Cameras, Antenna, and Enclosure Schematic at Bridge Site .....	71
Figure 20: Fire Sentry Corporation Flame Detector .....	72
Figure 21: Jenoptik Infrared Camera .....	73
Figure 22: Infrared Camera Image at Cutler-Donahoe Bridge.....	74
Figure 23: Infrared Camera Image at Holliwell Bridge.....	75
Figure 24: Panasonic Optical Camera.....	76
Figure 25: Optical Camera Image at Cutler-Donahoe .....	77
Figure 26: Optical Camera Image at Holliwell.....	77
Figure 27: Box Layout for NEMA Enclosure.....	78
Figure 28: Actual Box Layout in Field.....	79
Figure 29: Brackets for Box to Pole Connection .....	80
Figure 30: Cutler-Donahoe Pole .....	82
Figure 31: Cutler-Donahoe Flame Detector that is set off.....	82
Figure 32: Hogback Enclosure Set Up.....	83
Figure 33: Hogback Flame Detector.....	84
Figure 34: Original Hogback Pole .....	84
Figure 35: Wiring Diagram for an Off-Grid System with Solar and Wind Power.....	86
Figure 36: Assembly of 600 watt VAWT.....	88
Figure 37: Full Assembly of 600 watt VAWT .....	88
Figure 38: Promotional Picture of Solar Panel with Mounts.....	89
Figure 39: SRM-4D Battery Used for Battery Bank .....	90
Figure 40: Controller for Alternative Energy System.....	91
Figure 41: Controller Diversion Load.....	92
Figure 42: Samplex 24 VDC - 110 VAC Inverter .....	93

Figure 43: Modified Renewable Energy System .....	94
Figure 44: Holliwell Pole from Bridge .....	96
Figure 45: Holliwell Pole.....	96
Figure 46: Holliwell Flame Detector .....	97
Figure 47: Imes Pole from Bridge .....	98
Figure 48: Imes Flame Detector .....	98
Figure 49: Roseman Pole from Bridge .....	99
Figure 50: Roseman Pole .....	100
Figure 51: Roseman Flame Detector .....	100
Figure 52: Required Material for Flame Test .....	102
Figure 53: Flame Test Being Conducted .....	102
Figure 54: Flame Detector Prior to Alarm.....	103
Figure 55: Flame Detector after Alarm Set Off .....	103
Figure 56: Bigelow Covered Bridge .....	106
Figure 57: Knecht's Covered Bridge.....	107
Figure 58: Pomeroy-Academia Covered Bridge.....	108
Figure 59: Camera System Used on Cedar Covered Bridge.....	109
Figure 60: Red Covered Bridge .....	110
Figure 61: Schematic of NEMA 24"x 24" enclosure.....	114
Figure 62: Inside of Typical NEMA Enclosure .....	114
Figure 63: NEMA Enclosure Brackets for Pole Mount.....	116
Figure 64: Flame Detectors with and without Wood Coverings .....	118
Figure 65: Complete Pole after Installation .....	120
Figure 66: Hogback Renewable Energy System .....	123
Figure 67: Upgraded Renewable Energy System .....	130
Figure 68: Required Material for Flame Test .....	131
Figure 69: Flame Test Being Conducted .....	132
Figure 70: Flame Detector Prior to Alarm.....	132
Figure 71: Flame Detector after Alarm Set Off.....	133
Figure 72: User Interface for Decision Making Tool .....	138
Figure 73: Required Calculations for Decision Making Tool .....	139
Figure 74: Recommendations Page of Decision Making Tool.....	140
Figure 75: Example Required Questions for Decision Making Tool .....	142
Figure 76: Example Recommendations for Decision Making Tool .....	143
Figure 77: Example Budget for Decision Making Tool .....	144
Figure 78: Fire Sentry Corporation Flame Detector Specifications .....	158
Figure 79: Jenoptik Infrared Camera Specifications .....	160
Figure 80: Panasonic Optical Camera Specifications .....	162
Figure 81: Specifications for 600 watt VAWT.....	163
Figure 82: Specifications for Off-Grid Controller for Alternative Energy System .....	164
Figure 83: Drawings for Off-Grid Controller for Alternative Energy System .....	166
Figure 84: Specifications for 24 VDC-110 VAC Inverter.....	167
Figure 85: Specifications for Morningstar Solar Controller .....	169
Figure 86: Specifications for Conergy P 230PA.....	171

**LIST OF TABLES**

Table 1: National Historic Covered Bridge Preservation Program Budget (2000-2009).....	5
Table 2: Bridge Fires (1992-2002) .....	8
Table 3: NHCBPPA Budget Breakdown by State .....	145
Table 4: NHCBPPA Budget Breakdown by Year .....	151

## ACKNOWLEDGMENTS

First, I would like to thank my committee, Dr. Terry Wipf, Dr. Jennifer Shane, Dr. Loren Zachary, and Travis Hosteng for all of the assistance given on this thesis paper. Without their help and guidance the completion of this thesis would not be possible.

Furthermore I would like to thank Travis Hosteng, Nick Burdine, Justin Dahlberg, Doug Wood, Dr. Brent Phares, Owen Steffens, Peter Moreau, Allen Sievers, Connie Sievers, and Kyle Sievers for their hands on help with the installation of the monitoring system on the five bridges in Madison County. Without their help and knowledge the installation could not have been completed.

Finally I would also like to thank Todd Hagan, the county engineering for Madison County, who set up the trenching, pole installation, and electrical work at all the bridge sites. Without his help with setting up all of these utility workers our work would have been slowed dramatically at the bridge sites.



**ABSTRACT**

The design, construction and use of covered timber bridges is all but a lost art in these days of prestressed concrete, high performance steel, and the significant growth both in the volume and size of vehicles. Furthermore, many of the existing covered timber bridges are preserved only because of their status on the National Registry of Historic Places and/or the diligent maintenance and care of the owners of these structures. Of the covered timber bridges that remain in the United States, only a small percentage still stand today due to arson, vandalism, neglect, and other factors. The objective of this work is to provide covered timber bridge owners with the ability to quickly and efficiently design and implement a security system to protect these important historical landmarks. This goal was obtained with an in-depth analysis of equipment selected by the design team based on the practicality in a covered bridge application. Other major considerations that are required for all equipment to work efficiently within a security system are also fully discussed, including, but not limited to, maintenance, power requirements, and general set-up of an integrated security system. To further guide bridge owners and engineers, a decision making tool is presented to expedite the selection process based on financial abilities and security expectations of the covered bridge owner. Possible sources of funding for security projects are discussed including the requirements and benefits of a bridge being placed on the National Register of Historic Places. A comprehensive case study is presented involving monitoring systems placed on five of the six covered bridges in Madison County, Iowa at the end of this thesis to showcase the abilities of an integrated system and all the decisions that must be made throughout the process for the entire system to work as intended. The creative component portion of this thesis is satisfied with the installation of the monitoring system in Madison County, Iowa, with emphasis on the renewable energy system, and the completion of the decision making tool for covered bridge owners.

## CHAPTER 1 INTRODUCTION

Covered Bridges used to cover the American landscape from the Atlantic to the Pacific and are an iconic symbol of a developing America. However, due to various factors including: neglect, arson, vandalism, and natural disasters there are currently less than 700-900 bridges still in existence today according to differing sources. The isolated areas where covered bridges tend to be located as well as the building materials used to construct them make them highly susceptible to arson and vandalism. Due to the isolated nature of the bridges it is also difficult for firefighters to make it to the bridges once a fire has been set before the bridge is critically damaged or completely destroyed altogether. The fact that most of these covered bridges are covered by volunteer fire departments only adds to the response time once the fire has started. It is essential that we protect and preserve these standing landmarks throughout our county for future generations, one way to accomplish that is to use remote monitoring and other security systems to protect them from trespassers. This report is intended to assist covered bridge owners in designing complete systems that will protect and deter intruders while monitoring the bridge and alerting proper authorities to heighten the security at the bridge site.

### 1.1 Overview - Covered Bridge Surveillance Project, Iowa State University

In 2005, the Bridge Engineering Center (BEC) at Iowa State University (ISU) completed a case study on remote security monitoring of the historic Cedar Covered Bridge in Madison County, Iowa. The security system installed on the Cedar Bridge is discussed further in the Case Studies portion of this report. The work completed and the system developed for the Cedar Bridge resulted in the BEC receiving a grant from the Federal Highway Administration (FHWA) to install remotely monitored security systems on five covered bridges in Madison County and write a comprehensive report to address and document the security of covered bridges in the United States. The five bridges included in the security monitoring grant, the Cutler-Donahoe, Holliwell, Hogback, Imes, and Roseman covered bridges are five of the six landmark bridges which remain in Madison County and the only bridges that have not been completely rebuilt. The Hogback Bridge was partially damaged by

arson but managed to survive and was restored to its original condition one year after the incident. The Cedar Bridge, made famous by the book “The Bridges of Madison County”, was completely destroyed by arson in 2002 but rebuilt to original specification in 2003-2004 (Overington, 2003). An in-depth analysis of the security system for these five bridges and problems encountered can be seen in Chapter 9 Madison County Project later on in this report.

## **1.2 Scope of Work**

This manual is intended to fulfill the requirements outlined by the FHWA for security systems for covered bridges. The research team has completed an extensive government literature review at the local, state, and federal levels which included contacting several Departments of Transportation (DOT) and local governments with a high concentration of historic covered bridges that have installed, or are planning to install, security systems or other preventative measures on their bridges. Multiple companies that specialized in outdoor security systems were contacted to determine cutting edge technologies in the security industry at the time this report was written. Note that this manual is not intended to be an all-inclusive list of possible security system equipment and tactics, but a guide to best practices, techniques, and equipment for use in any given bridge security system. As advancements in security equipment technologies arise, it is ultimately the responsibility of the security system designer and/or bridge owner to develop a system which provides the best protection possible for each covered bridge.

## **1.3 Creative Component**

The creative component for this thesis differed from many others within the discipline of Structural Engineering since the project did not work with any structural properties of the covered bridges. Satisfaction of the creative component requirements put forward by the Graduate College at Iowa State University was accomplished with the installation of all equipment on the Madison County Project, with emphasis on the renewable energy system, and the decision making tool that will be available within the report given to covered bridge

owners throughout the United States. The set-up of the Madison County Project can be seen in Appendix A Creative Component: Installation of Security System in Madison County and the decision making tool can be seen in Appendix B Decision Making Tool.

Both of these components required considerable creativity and an extensive engineering background. The set-up of the monitoring systems on all bridges required a background in Construction Engineering with scheduling and estimating of several different activities simultaneously with several different contractors and government entities. Installation and troubleshooting of the renewable energy system at Hogback Covered Bridge required in-depth analysis of the electrical requirements and abilities of the system where several of these equations are shown in A.5.3 Troubleshooting of Renewable Energy. A structural engineering analysis was also required on the telephone pole that was used for the wind turbine and solar panel to ensure that the forces on the pole would not exceed the poles structural limitations.

## **CHAPTER 2 LITERATURE REVIEW**

The literature review portion of this report was difficult given the lack of technical writing dealing exclusively with covered bridges. Although there is a lack of literature there are still numerous professionals throughout the country that have substantial knowledge dealing with covered bridges and were a great asset during the writing of this report. Multiple DOT's and local governments with a high concentration of covered bridges were contacted about previous security installments at covered bridges and their insight and knowledge were invaluable in the writing of this report. The experience of the design team at ISU with constructing two different types of security systems for six bridges was also heavily relied upon for major portions of this report.

### **2.1 Previous Literature with Covered Bridges**

Recently, the federal government as well as multiple state and local governments have placed significant emphasis upon preserving our covered bridges. There is money being allocated every year to covered bridge rehabilitation and preservation through Federal Funding as well as state and local funding. With this amount of money going towards the preservation of covered bridges it is important the proper steps be taken in order to keep them secure. Appendix A in this report has the National Historic Covered Bridge Preservation Program's (NHCBPP) budgetary spending broken down by state (Table 3) and by year (Table 4). A simple overview of the NHCBPP's budget can be seen in Table 1 broken down in to a gross budget per year from 2000-2009.

**Table 1: National Historic Covered Bridge Preservation Program Budget (2000-2009)**

<b>Year</b>	<b>Amount Awarded</b>
<b>2000</b>	<b>\$7,000,000.00</b>
<b>2001</b>	<b>\$9,049,486.00*</b>
<b>2002</b>	<b>\$2,822,750</b>
<b>2003</b>	<b>\$5,608,435**</b>
<b>2006</b>	<b>\$10,083,451</b>
<b>2007</b>	<b>\$8,742,317.32</b>
<b>2008</b>	<b>\$8,307,000.00</b>
<b>2009</b>	<b>\$8,507,643.11</b>
<b>2000-2009</b>	<b>\$60,121,082.41</b>

\* Total funding appropriated was \$9,978,000 but \$928,514 was set aside for research and \$9,049,486 for bridge preservation.

\*\* \$352,565 was reserved for research and education

The Transportation Equity Act (TEA-21), as amended by the TEA-21 Restoration Act, established the NHCBBP. The NHCBBP preserves covered bridges listed, or eligible for listing, on the National Register of Historic Places. A portion of this funding is put towards research on how to better protect and restore covered historic bridges throughout the United States (Pierce, 2005). The NHCBBP, supported by the FHWA, created a document in 2005 titled "Covered Bridge Manual" that extensively covered the structural properties of covered bridges and how to improve them. This text can help bridge owners with the steps necessary to structurally strengthen their bridge and make it more resistant to arson and vandalism. The National Historic Covered Bridge Preservation Program was not authorized for Federal Funding for the fiscal years of 2004 and 2005. Therefore, the program did not exist during those years.

## **2.2 The Beginning of Covered Bridges in the United States**

The first covered bridges in the United States appeared in the Eastern States in the early 1800's and were continually built all over the country until the early 1900's when steel bridges became the more economical choice for bridge construction. As bridge and road design became routine and repetitive the distinctive architecture of covered bridges started to stand out more and more when compared to its modern counterpart. Although new construction of covered bridges ceased toward the turn of the 20th century they were still

used well into the new century and many continue to be renovated and repaired for use today and well into the future. Despite the best efforts to preserve the bridges at the turn of the 20th century, many covered bridges were lost to neglect, fire, flooding, and other disasters both natural and manmade (Becker).

### **2.3 Structural Integrity**

Designers found out that by covering the heavy and expensive, wooden structural trusses from the direct rainfall and sunlight the life expectancy of the bridge could be extended up to three times longer than a non-covered bridge. Although the sacrificial wall and roof coverings would have to be replaced every couple of decades it was still a more economical choice than completely replacing the bridge or structural trusses in the same time frame. The ability to extend the life of wooden truss bridges by using sacrificial wall and roof coverings was discovered early in the age of bridge design while in Europe and other parts of the world and was an integral part of the wooden bridge when it arrived in North America (Becker).

### **2.4 Targeting Covered Bridges: Arson and Vandalism**

It is estimated that there are over 176,000 intentional outdoor fires set by arsons every year. These fires result in approximately 20 deaths, 250 injuries, and \$23 million in losses annually according to Volume 9, Issue 6 of the Topical Fire Report Series. Out of all the outdoor fires that occur every year in the United States, twenty-seven percent are intentionally set by arsonists (National Fire Data Center, 2009). Arson is a prevalent problem in the United States that destroys property and life and must be addressed in a serious manner. Intentionally set outdoor fires tend to be more common in the spring from March and April and once again in mid-summer, especially July 3-5 according to The National Fire Incident Reporting System (NFIRS). Since these are the times when arson is most likely to occur it is recommended that, at a minimum, the highest level of security active during these time periods.

These devastating effects are evident when arson is committed on covered bridges in small

towns all over the country. Unfortunately this kind of damage is prevalent throughout recent history as seen in Indiana (Rinehart, 2005), Iowa (Overington, 2003), and Pennsylvania (Murphy, 2008). The number of covered bridges throughout the United States is quickly dwindling due to these acts of arson as well as neglect on the part of the city or bridge owner. On average, over the last twenty to thirty years, there have been two to three bridges apparently set on fire by an individual or group of people with one or two of these bridges being completely destroyed, as shown in Table 2. It is essential that cities and states that own and maintain covered bridges take the proper measures to ensure that these bridges will survive for future generations to enjoy.



**Table 2: Bridge Fires (1992-2002)**

Year	Bridge Name	Comments
1992	Loy's Station	
1992	Parker	Survived
1993	Slate Bridge	
1993	Jordan	
1993	Corbin	
1993	Smith	
1993	LeMay Ferry	
1993	Nectar C.B.	
1993	Sells	
1993	Kilgore Mill	
1994	Wolf Bridge	
1994	Grimes	
1994	Guilford	
1994	Kaufman's Distillery	
1994	Upper Sheffield	
1995	Miller Road	Survived
1996	Wimer	Survived
1996	Carman	
1997	Offult Ford	
1997	Lower	
1997	Wilkinson	
2000	Henniger Farm	Survived
2001	Pine Grove	Survived
2002	Ryot Bridge	
2002	Orne Bridge	
2002	River Road	
2002	Cedar Bridge	
2002	Henderson	Survived
2002	Risser's Mill	
2002	Jackson	Survived
2002	Jeffries Ford	
2002	Woodsville	Survived
2002	Newfield	Survived
2002	Wilson's Mill	Survived

\*Wilson's Mill Covered Bridge (Avella, Pennsylvania) thought to have survived due to a metal deck

### 2.4.1 Indiana

In 2005 a fire destroyed one of the 31 covered bridges remaining in Park County, Indiana. The Bridgeton Bridge was known as the most photographed bridges in the county before the fire and was beloved by all in the area. A 35-year-old male who was a person of interest in an arson case with another covered bridge in the area seemingly poured an accelerant across the length of the bridge and ignited it sometime around midnight. Both of the bridges that were ignited due to arson were completely destroyed and collapsed. Firefighters were able to save another bridge, a few months prior to these arson cases, which also appeared to be intentionally set (Rinehart, 2005).

### 2.4.1 Iowa

Madison County, Iowa is well known for their covered bridges due to the popularity of the book *The Bridges of Madison County* by Robert James Waller and the movie adaption with leading actors Clint Eastwood, Meryl Streep, and Annie Corley. None of the six remaining covered bridges in the county were made as popular by the book as the Cedar Bridge, which is on the cover of the book and a central bridge throughout the entire story. On September 3, 2002 the Cedar Bridge was completely destroyed by arson, only four years after over \$128,000 was put into the bridge for restoration. The town was extremely distraught over the loss of the bridge given the large amount of tourism it brought to the community and the manner in which it was destroyed. This prompted the city to replace the structure with an exact replica with as similar of construction techniques as possible the next year (Overington, 2003).

### 2.4.3 Pennsylvania

One of the three remaining bridges in Erie County, Pennsylvania was set ablaze in December, 2008 by two local men. The destruction of this particular bridge was damaging to the city for two separate reasons. The historic Gudgeonville Covered Bridge in Girard Township was valued at over \$1 million and was of great importance to local tourism and also a vital part of the roadway system that still carried traffic over the Elk Creek. Both of the

men responsible for these crimes were suspects in other crimes throughout the area including burglary, criminal trespass, and unlawful taking that are all unrelated to the bridge incident (Murphy, 2008).

## **2.5 Importance of Historical Integrity**

It cannot be stressed enough that any modifications completed on covered bridges including security systems or any other type of rehabilitation must be done with the greatest of care to ensure that the historical significance of the covered bridge is preserved. The National Register of Historic Places has strict guidelines as to what will and will not be accepted as a historical place and what will not. In order to be eligible for some funds from government agencies to preserve a covered bridge it is important that a covered bridge is on the register of historic places before and after any modifications. The National Register of Historic Places has the following criteria that must be met for all historic places:

### *2.5.1 Criteria for Evaluation of Being on the Register of Historic Places*

The quality of significance in American history, architecture, archeology, engineering, and culture is present in districts, sites, buildings, structures, and objects that possess integrity of location, design, setting, materials, workmanship, feeling, and association, and the following:

- That are associated with events that have made a significant contribution to the broad patterns of our history; or
- That are associated with the lives of significant persons in or past; or
- That embody the distinctive characteristics of a type, period, or method of construction, or that represent the work of a master, or that possess high artistic values, or that represent a significant and distinguishable entity whose components may lack individual distinction; or
- That have yielded or may be likely to yield, information important in history or prehistory

### *2.5.2 Benefits of Being on Register of Historic Places*

Listing in the National Register of Historic Places provides formal recognition of a property's historical, architectural, or archeological significance based on national standards

used by every state. Results include the following:

- Becoming part of the National Register Archives, a public, searchable database that provides a wealth of research information.
- Encouraging preservation of historic resources by documenting a property's historic significance.
- Providing opportunities for specific preservation incentives, such as:
  - Federal preservation grants for planning and rehabilitation
  - Federal investment tax credits
  - Preservation easements to nonprofit organizations
  - International Building Code fire and life safety code alternatives
- Possible State tax benefit and grant opportunities. Check with your State Historic Preservation Office for historic property incentives available within your state.
- Involvement from the Advisory Council on Historic Preservation when a Federal agency project may affect historic property.
- Find out information on the care and maintenance of your historic property through various NPS Preservation Briefs and Tech Notes.
- Network with other historic property owners, tour historic areas, or chat with preservationists through Conferences, Workshops, and Preservation Organizations.
- Celebrate your listing by ordering a bronze plaque that distinguishes your property as listed in the National Register of Historic Places

## CHAPTER 3 PHYSICAL SECURITY OF STRUCTURES

Physical security is a basic principle necessary for the survival of any person, place or object. Throughout history people have used security to protect their privacy, property, and lives whether it be a sharpened stick to keep animals away, constructing large impenetrable walls, or more recently the use cameras or other monitoring devices to detect and apprehend ill willed individuals. By definition, security means the freedom from danger, fear, or anxiety (Merriam Webster Dictionary). By this definition alone, security covers a wide array of areas including information, physical, political, monetary, as well anything that requires protection from danger. To some degree there is a concept of security dealing with almost all areas of life which makes it difficult to cover security in depth at all levels.

Structures can come under attack from terrorism, sabotage, natural disasters, and other danger that may be unique to a particular area. It is essential that when designing a security system for a certain structure that a full analysis is done in order to ensure that the level of security required is obtained. Designing a security system for any structure is always a case of planning for unknown dangers in type and magnitude, with the understanding that not all security risks and dangers can be prevented, deterred, or even detected.

### 3.1 Blue Ribbon Panel Workshop on Bridge and Tunnel Security

A Blue Ribbon Panel (BRP) Workshop for the Federal Perspective of Bridge Security Assessments met in 2003 following the terrorist attacks of September 11, 2001 to analyze the safety of the transportation infrastructure (The Blue Ribbon Panel on Bridge and Tunnel Security, 2003). It was given the objective to “Develop short- and long-term strategies for improving the safety and security of the nations’ bridges and tunnels, and provide guidance to highway infrastructure owners/operators.” The BRP decided upon five major levels of security to construct an effective defense against unwanted activities on or towards bridges. These levels include deterrence, deny access, detect presence, defend the facility, or design structural hardening to minimize consequences to an accepted level. The BRP report goes into detail with designing structural hardening but does not go into much detail about the

other four areas.

Although all levels of security are not equally discussed in full detail within the BRP workshop report, the research team felt it was prudent to investigate and discuss all five levels of security in greater detail. By considering all five levels of security when developing a security system for a bridge, or any other structure, the owner is able to assemble a system that is not only effective, but redundant and that provides the greatest level of security possible for the given budget. Within this report the concept of structural strengthening covered only briefly since there are several different publications that look at structural hardening of bridges and covered bridges in particular. This report's main goal is to compliment these publications with the other four main portions of security discussed within the BRP's Assessment. Below, these four levels are briefly discussed; furthermore, multiple examples of each of the areas are discussed within the equipment options portion of this report.

### *3.1.1 Deter*

Deterrence is the prevention or discouragement of a detrimental action by means of fear or doubt. For the case of bridge security the fear would be that anyone who would commit detrimental actions to the bridge would be caught and prosecuted or would be unwilling to commit the crime because of certain security devices installed on site. One of the more inexpensive options for deterrence would be to place signs around the bridge alerting all visitors that there is surveillance equipment and alarms implemented on site and local authorities will be alerted of any trespassers after hours.

### *3.1.2 Deny*

Denying trespassers from the bridge site is one of the more difficult portions of the security program laid out by the Blue Ribbon Panel. Since most covered bridges are in secluded, forested areas there are several different ways for trespassers to enter the site. Many of the methods used for deterrence can also be able to deny trespassers to a limited degree. The use of fences and barricades around the bridge area could deny, or at least slow down, any

potential threats to the bridge.

### *3.1.3 Detection*

In the case of arson and vandalism, surveillance of the bridges is a great first step in the detection; in addition, other steps can be taken to lessen the probability of total destruction of the bridge, as will be discussed further. Many of the proposed equipment options located in the preliminary decisions portion of this report all pertain to detection of threats. The detection of threats can be an invaluable portion of the security system since most bridges are located in isolated areas where it might not be visible from roads or residential areas. This makes it important that local authorities are alerted if there is anything going on at the bridge site.

### *3.1.4 Defend*

The ability for the covered bridge to defend itself once a fire has been is essential for the survival of the bridge. There are multiple ways to defend a bridge such as sprinkler systems or fire retardant paint or wood during construction or renovation. Defense is fundamentally different from structural strengthening since the addition of these devices do not change the bridge in a structural sense but only protect the existing structure from fire. The addition of a steel bridge deck is an example of structural strengthening. A steel bridge deck will allow the bridge to withstand greater loads but will still give the bridge a great chance to survive if a fire has been set.

## CHAPTER 4 COVERED BRIDGE MONITORING SYSTEM: DESIGN

### 4.1 Preliminary Decisions

There are multiple decisions that must be made in order to construct an effective security system that can fulfill the needs and desires of each respective bridge owner. Some of these main decisions are discussed in full detail within this section. It is important to realize that these lists are not intended to be all inclusive. Illustrated in Figure 1 are some of the more major decisions that go into designing a security system. Subsequent sections provide more detail regarding the information and terms presented in Figure 1 to give the designer a more in-depth look at what goes into each part of the system.

Any equipment or components that are used on or around the bridge site must be carefully selected such that they do not detract from the aesthetic value of the bridge and survive in a hostile environment, all the while providing acceptable levels of performance with minimum maintenance. These criteria prove to be the most important aspects of any equipment choice for most covered bridge applications. All components of the security system that are located on the bridge site should be weather resistance, resistant to the constant abuse of insects or animals, and the destructive actions of any trespasser onto the bridge site. An in depth look into what must be done in order to adequately protect all equipment is discussed in further detail in the Set-up section of this report.

All of the following equipment explanations are designed to be a brief overview and not a complete narrative. There are multiple sources such as online reviews and other publications that can assist the security system designer when deciding on equipment options and their abilities and draw backs. Detailed communication with all equipment manufacturers ensure that all devices can be integrated effectively and meet or exceed the requirements of the bridge owner.



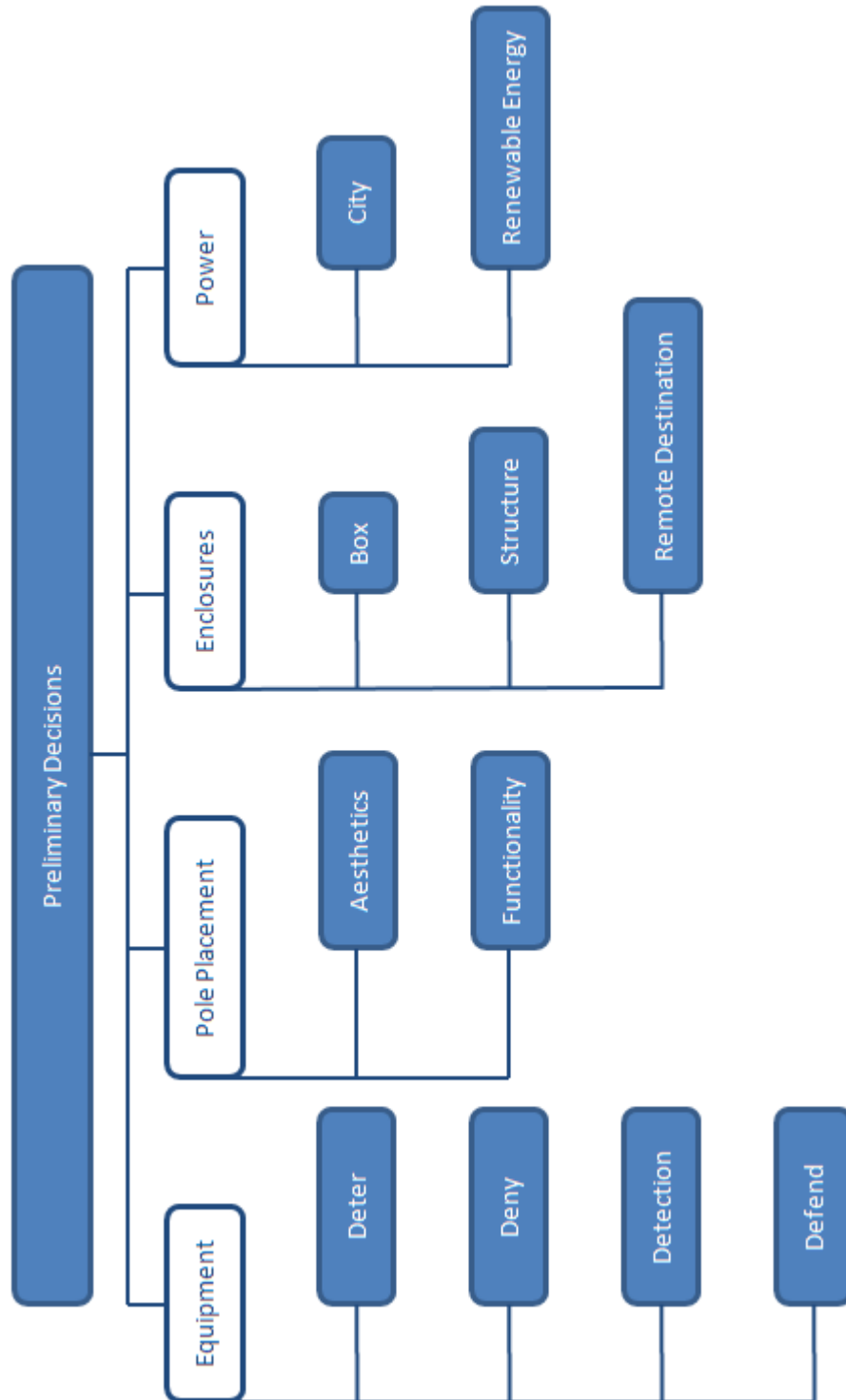

**Figure 1: Equipment Options**

## 4.2 Equipment Options

There are multiple options for equipment that can be used on any particular security system. The following list of possible pieces of equipment is not intended to be an all-inclusive list but more of a list of typical pieces of equipment that should be considered for the application of bridge security. Each covered bridge is unique in its aesthetics, structural design, and surrounding landscape so there may be equipment listed here that would not be applicable to a specific bridge. The designer of the security system for a particular bridge should be sensible and rational about what pieces of equipment are selected for the security system. In later sections of this report it is discussed which systems will be best utilized for different locations and situations.

None of the equipment listed below is intended to be used completely by itself to protect a structure, there needs to be an integration of several pieces of equipment that work together to protect the bridge as efficiently as possible. The five areas of security that are listed by the BRP deter, deny, detect, defend, and structural strengthening cannot be obtained with a single piece of equipment. Any one piece of equipment may only provide one or possibly two types of security; therefore, to obtain optimal levels of security it is essential to use multiple pieces of equipment that have multiple abilities as shown in Figure 2.

A decision making tool, shown in Figure 3, was created in order for bridge owners to make quick decisions about the type of security system to be installed on a particular bridge with a given budget. All prices are considered to be average prices and may be significantly higher or lower depending on the abilities of the equipment and the specific manufacturer. Each piece of equipment that is listed in this tool is expanded upon in this section with capabilities and limitations of all equipment.

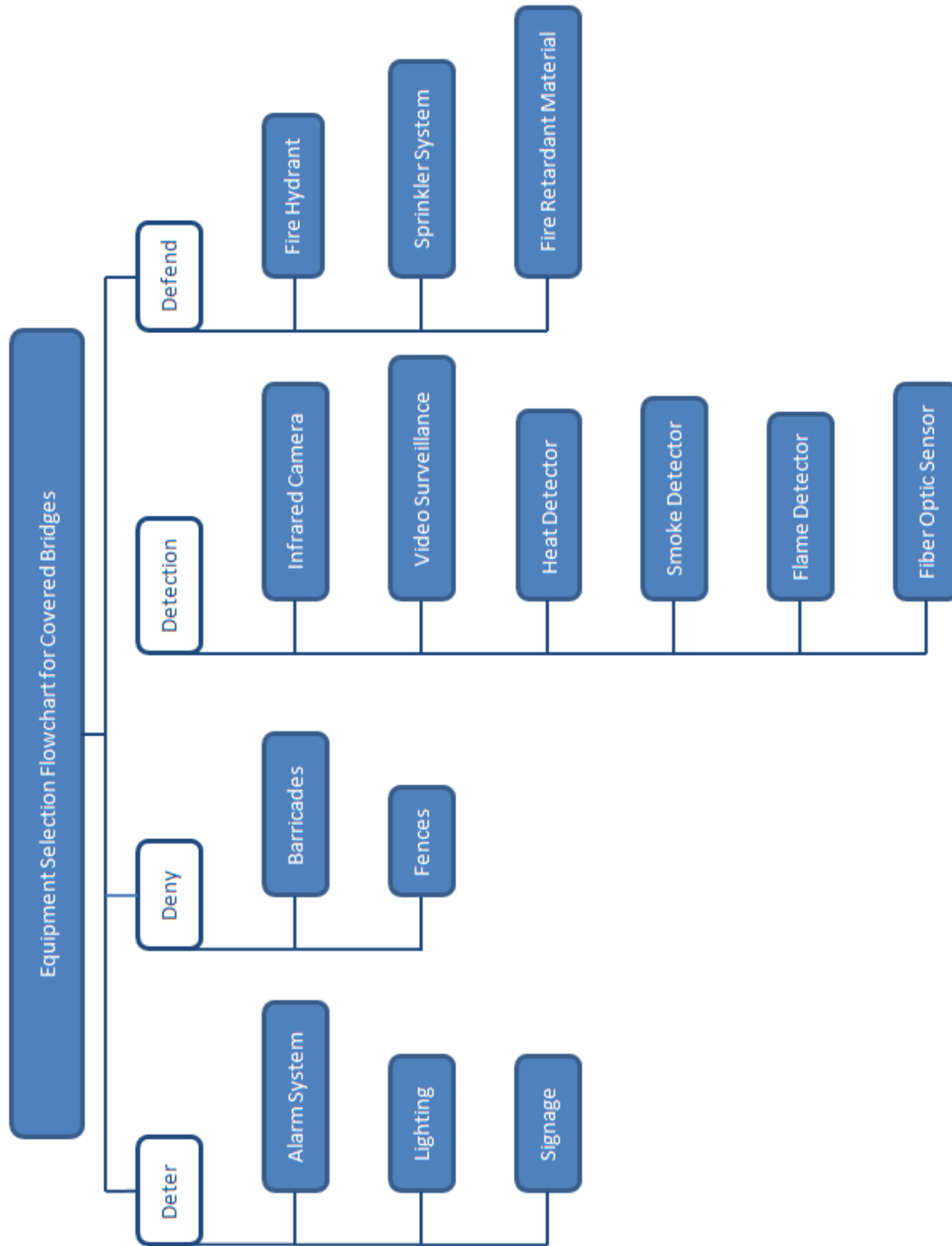

Figure 2: Flowchart of Equipment Options

	Equipment	Average Price	Average Capabilities	Main Drawbacks	*Requirements	Maintenance
Deter	<b>Alarm System</b>		Audible/Visible signals at structure Notify proper authorities	Possibility of false alarms at bridge site Can notify trespasser and allow escape	Low electrical draw Enclosure for communication	Monthly
	Annunciator Panel	\$300				
	<b>Lighting</b>	\$70/fixture	Make portions of bridge site visible day/night Allow cameras to see during low light levels	Can lead to light pollution	Moderate electrical draw	Yearly
Deny	<b>Signage</b>	\$50	Inform trespassers of consequences	May be difficult to move when necessary		Rare
	<b>Barricades</b>	\$300	Limit traffic to certain sized vehicles Stop traffic altogether from entering bridge			Rare
	Decorative Planters	\$300				Rare
	Bollards	\$150				Rare
	<b>Fences</b>	\$15/foot	Limit access points at bridge site	Cannot completely limit access points		Rare
	Chain Link	\$8/foot				Rare
	Wood	\$10/foot		Rot and warping of wood may occur over time		Yearly
	Wrough Iron	\$25/foot				Rare
	Block Wall	**\$10/SF				Rare
	<b>Infrared Camera</b>	\$5,000	Monitor temperatures within field of view View bridge regardless of amount of light	False alarms due to glare, animals, or heat Sensitive to environment	High electrical draw Pole	Yearly
Detection	<b>Video Surveillance</b>	\$300	Allow remote parties to view bridge	Dependent on lighting in field of view	High electrical draw Pole	Yearly
	<b>Heat Detector</b>	\$100	Monitor temperatures around detector	False alarms due to environment	Moderate electrical draw	Yearly
	<b>Smoke Detector</b>	\$50	Monitor smoke levels around detector	Highly vulnerable to exterior conditions	Low electrical draw	Monthly
	<b>Flame Detector</b>	\$1,500	Monitor temperatures within field of view	False alarms due to glare, animals, or heat	Moderate electrical draw	Yearly
	<b>Fiber Optic Sensor</b>		Monitor temperatures along length of device	Possible difficult with installing	Moderate electrical draw	Yearly
Defend	<b>Fire Hydrant</b>	**\$3,000	Provide water source to fire department	Requires close water supply	Close water supply	Yearly
	<b>Sprinkler System</b>	**\$15,000	Extinguish fires started within interior of bridge	Bulky and not aesthetically pleasing Loss of effectiveness over time	Close water supply	Yearly
	<b>Fire Retardant Material</b>	\$8/SF	Stop or slow the ignition of a fire Stop the spread of any fires that may start	Loss of structural strength to applied		Every few years

**Notes:**

- \* Draw requirements are as follow
  - Low: 0.01 - 0.2 amps AC
  - Moderate: 0.25 - 0.49 amps AC
  - High: 0.5+ amps AC
- \*\* Includes installation

Figure 3: Equipment Selection Tool

### 4.2.1 Deter Equipment

#### 4.2.1.1 Alarm System (Tyska, 2000, Chapter 104)

Any of the above pieces of security equipment, either stand-alone or together in a system, are nothing more than hardware without the integration of a carefully designed alarm system. Tyska discusses alarm systems in great detail in Physical Security 150 Things You Should Know and was the main source of information for this report. There are several different alarm systems that may be used depending on the intent and level of security. The different types of systems can include alarms that silently send out an alarm to the proper authorities, a system that emits an audible alarm in the area of the bridge as well as some type of visual alarm, or a combination of the two. Several different issues may factor into the decision on what type of alarm system to use, such as the bridge's proximity to local authorities and to residential areas. If the bridge is in close proximity to a residential area it may not be attractive to have a loud, audible alarm that could disturb residents for all alarms, real and false. The proximity to the local authorities, more specifically their response time, is also a key factor in the decision of the type of alarm system. If the bridge is within a reasonable distance to the proper fire department and police station it may be more appropriate to have a silent alarm that will only alert the local authorities and give them the possibility of apprehending the criminal. If there is more considerable distance between the bridge and the local authorities or if the fire is protected by a volunteer fire an audible alarm may alert both the criminal and nearby local public with the intent of deterring the criminal before more damage is inflicted to the structure.

The standard alarm system consists of the following:

- Detection elements located at the protected area, designed to initiate alarm upon entry of an intruder.
- Transmission lines, which conduct signals to a device in the immediate area or to a central annunciator panel that can be continuously monitored.
- A panel which announces by visible and/or audible signals the structure or area in which an alarm has been activated.
- Fail-safe features that provide a signal at the annunciator panel if any part of the system is malfunctioning.

#### 4.2.1.2 Lighting (Tyska, 2000, Chapter 24)

Most vandalism and arson is committed during the nighttime hours because the trespassers are disguised by the darkness. Adequate lighting at the bridge site at all times can prove to be a cost effective and efficient way of protecting the bridge. Tyska discusses lighting in great detail in Physical Security 150 Things You Should Know. It is important that the right amount of lighting is used in order for it to be effective yet without contributing to any light pollution which could be unattractive and costly. There are many guidelines that can be used in order to limit light pollution on the bridge site including the use of sensors, timers, high efficiency fixtures, directional fixtures, as well as multiple others. It may also be more economical in the long run for a professional, who has experience with exterior lighting, to design your lighting system.

Proper lighting should be used in unison with an optical camera to improve effectiveness. There are multiple types of lighting that can be used in a variety of situations. They include the following:

##### 4.2.1.2.1 Perimeter Lighting

This type of lighting is used to illuminate the fence or perimeter of a certain site. The perimeter for this application could be at a certain distance from the bridge or be the perimeter of the bridge itself. Perimeter lighting is used so that trespassers must pass through an adequately lit perimeter that may or may not be under surveillance. This is to act as a deterrent for the trespassers.

##### 4.2.1.2.2 Area Lighting

This type of lighting is used to illuminate the area surrounding the bridge that must be passed through in order to enter the bridge. Much like perimeter lighting, area lighting is used as a deterrent to trespassers by having to pass through brightly lit areas in order to reach the bridge.

#### 4.2.1.2.3 Floodlighting

Floodlighting is used to saturate an entire area with bright lighting to deter trespassers. This type of lighting may detract from the aesthetics of the bridge and distract people driving by the bridge and people that live near the bridge site.

#### 4.2.1.2.4 Gatehouse Lighting

This type of lighting involved illuminating entrances and exits to and from the site. This is essential for the entrances of both sides of the bridge as well as entrances to major roadways around the bridge site.

#### 4.2.1.3 Signage (Tyska, 2000, Chapter 89)

Placing signage around the entrances of the bridge site stating that anyone who enters after nightfall or attempts to deface the bridge will be prosecuted to the fullest extent of the law is an effective way of deterring trespassers. Signage stating that there is a surveillance system on site that is running 24 hours a day should also be considered for added protection and deterrence. The more signage that is present on the site, the more likely it is that people entering the site will see them. Tyska discusses the usage of signage in great detail in [Physical Security 150 Things You Should Know](#)

### 4.2.2 Deny Equipment

#### 4.2.2.1 Barricades (Arata, 2006, Chapter 4)

Michael Arata discusses barricades in full detail in the book [Perimeter Security](#). Many covered bridges today are closed to motor vehicles in order to reduce live loads on the bridge. It is important to have adequate protection at the bridge site to deter motor vehicles from entering the bridge site in areas where the dynamic loading can be detrimental to the structure and cause severe damage. Barricades can provide an appropriate level of protection at the entrances of the bridge and also anywhere else where the bridge owner would like to prohibit the movement of motor vehicles. There are several different options when deciding upon which barrier will be the most appropriate at any given bridge site including natural and

man-made options.

#### 4.2.2.1.1 Natural Barriers

The bridge owner does not have a lot of influence on what type of natural barriers are present at the bridge site. In most cases these types of barriers cannot be moved or changed in any major ways because of physical limitation, aesthetics, or environmental regulations. The security system designer should be able to utilize the natural barriers to enhance the security at the site and minimize any negative influence they may have over the system. There are many different types of natural barriers that will be unique to every bridge site. Examples of possible natural barriers that may be present at any given site are as follows:

- Rivers

Many covered bridges were used to span over rivers so this will be a typical natural barrier that will occur at many bridge sites unless the bridge was moved to a safer location. Rivers are an effective way of keeping trespassers out from underneath the bridge.

- Thick brush

Much like rivers, most covered bridges are in heavily forested areas where there will be vegetation close to the bridge site. Some may consider this to be a nuisance but thick brush can act as a natural barrier that will keep out motor vehicles and, in many cases, trespassers. The security system designer can choose to plant hedgerows in strategic areas to deny or deter trespassers from entering certain areas of the bridge including underneath the bridge itself where major damage could be committed.

- Mountains

Some bridges may be in mountainous areas where sheer rock walls or other features can be present around the bridge site. Sudden changes in elevation can aid the



security system since many trespassers would be deterred by having to climb a large shear wall or incline.

- Ravines and Canyons

Much like mountains, ravines and canyons will deter many trespassers with the fact that they would have to navigate over a tumultuous landscape.

#### 4.2.2.1.2 Man-Made Barriers

As mentioned earlier, there are several different options for barriers to be chosen by the security system designer. Some options may not be reasonable at all sites but some possible options for barriers are as follows:

- Decorative planters

The use of decorative planters can take multiple shapes whether it is as a planter or a bench. The main advantage of using a decorative planter is that it is aesthetically pleasing as well as an efficient barrier. They will deter motor vehicles from entering the bridge site but can be moved by a forklift or other heavy machinery in case someone with authority needs to enter the bridge for any reason.

- Bollards

There are many types of bollards including fixed, removable, and retractable. A bollard is a cylindrical tube that is usually 12 to 24 inches in diameter and can vary on how far it sticks out of the ground. There is a wide range of material that the bollard can be including wood, concrete, steel, or plastic however plastic would not be a very suitable option for a covered bridge site.



Source: [http://www.bollardsolutions.com/steelpipe\\_sleeves.htm](http://www.bollardsolutions.com/steelpipe_sleeves.htm)

**Figure 4: Different Types of Bollards Installed**

- K-rail

Also known as Jersey barrier since it was first used on the New Jersey Turnpike, K-rail is used to deflect motor vehicles safely. Due to the negative aesthetic impact on the bridge site the K-rail will more than likely not be an ideal solution for a barrier.



Source: <http://midstateconcrete.com/product/178/10%27-K-Rail.html>

**Figure 5: Standard K-rail**

- Welded steel guard rails

Much like the K-rail, the use of welded steel guardrails may not be the choice of preference due to its negative aesthetic value. Although it may have not been aesthetically pleasing, the use of steel guardrails is a cheap and effective way to protect the entrance to the bridge.

- Berms/ditches

One of the simplest ways of creating a barrier is to simply have a ditch or berm around an area that is off limits. This may not be as effective as other means since some motor vehicles may be able to navigate over or around a ditch or berm.

#### 4.2.2.2 Fences (Arata, 2006, Chapter 3)

Michael Arata discusses fences in full detail in the book Perimeter Security. The use of a fence at a bridge site would prove to be advantageous to a bridge owner so that the public would only be able to enter the bridge site through secure entrances that can be monitored and controlled. Fences are not supposed to be thought of as way of completely preventing

unwanted entry into the bridge site but a way of slowing down and deterring any trespassers and forcing them through secure entrances and exits that may or may not be under surveillance.

When deciding to build a fence there are many decisions to be made depending on the type of bridge site that is being secured including the following:

#### 4.2.2.2.1 Chain Link

Chain link fences are the most common type of perimeter fences due to their price, easy set-up, and low maintenance requirements. The chain link fence is so functional that the federal government widely uses it and has the following specifications that can be found in Federal Standard RR-F-191/1A. The following is a summary of federal specifications taken from Defense Logistics Agency (DLAI 5710.1):

1. Fabric made of chain link
2. No. 9 gauge or heavier wire
3. Seven feet high
4. Fence fabric mounted on metal posts set in concrete
5. Mesh openings not larger than 2 square inches
6. Fence bottom within 2 inches of solid ground
7. Fence top guard strung with barbed wire, and angled outward and upward at a 45-degree angle

The fabric used for the chain link fence should be galvanized, aluminized, or plastic-coated woven steel. The fabric should be connected to the posts with the same gauge wire that the fabric itself is made out of. Therefore if the wire is constructed of 8 gauge steel then the wire connecting it to the fence post should also be 8 gauge. If a fabric is used that has openings larger than 2 square inches then the fence itself will be much easier to climb for intruders and should be avoided when possible. The use of privacy slats are commonly used with chain link fences but should be avoided on bridge sites since it allows intruders the ability to approach the fence without detection from the outside.



Source: [http://www.reliablefenceco.com/chain\\_link\\_fencing/commercial.html](http://www.reliablefenceco.com/chain_link_fencing/commercial.html)

**Figure 6: Chain Link Fence with Barbed Wire at 45-Degree Angle**

These are specifications for federal use and are not required by bridge owners for installation of chain link fences but are good guidelines to be used in order to make an effective perimeter. The use of barbed wire for extra security may not be required since most bridge sites will not need this high level of security.

#### 4.2.2.2.2 Wrought Iron

The wrought iron fence is growing in popularity but is used mainly as an upgrade to chain link fences and is used mainly in residential areas for more decorative perimeter fences. The top of the fence is typically bent towards the outside of the area being contained and sharpened ends for added security. It can be more difficult to climb a wrought iron fence when compared to a chain link fence, especially a chain link fence without barbed wire, but the added cost that a wrought iron fence brings may dissuade a bridge owner from deciding to go with this type of fence.

#### 4.2.2.2.3 Wood

There are many options when using wood fences including design and level of security. Most wood fences do not allow a clear line of site to the other side of the fence, which is not desirable on a bridge site. With this lack of vision and the increase in maintenance required

when compared to steel fences, wood fences are not typically an option decided upon when providing a perimeter fence for a bridge site.

#### 4.2.2.2.4 Concrete or Block Wall

Much like the wood fence, when using concrete or block walls there are many options to be decided upon since each wall is unique. Many concrete walls have barbed wire on top for added security but this is not a requirement. Concrete or block walls will be a significant price increase from a steel fence and will take longer to install and therefore it is not typically an option decided upon when providing a perimeter fence for a bridge site.

### 4.2.3 *Detection Equipment*

#### 4.2.3.1 Infrared Camera

An IR camera has the ability to see images and record the temperatures of different elements within its field of view during times of the day with inadequate sunlight such as dusk or nighttime. This key element to the IR camera makes it invaluable to this project since most acts of arson and vandalism occur during times of the night where the perpetrator can be masked by darkness. The major drawback for installing an IR camera at a bridge is the inherent cost when compared to other surveillance equipment.

IR cameras have the ability to set off alarms at certain temperature thresholds, certain rates of temperature change, and motion detection. It is important that great care is taken when using a motion detection device, even in the nighttime when people are not allowed on the bridge, because most bridges are in isolated, wooded areas where several large animals such as deer or bears could enter the field of view of the camera and set off the motion detector resulting in a false alarm. This same reason is why the threshold temperature should be chosen wisely since most large animals that could be present around the bridge site will have comparable body temperatures. Another reason to properly adjust the threshold temperature has to do with the type of wood preservative used on the bridge. Researchers at Iowa State University had problems with false alarms at certain thresholds because the bridges being researched

used creosote to preserve the wood members. During the summer days the creosote would be heated up by the sun and did not dissipate enough heat by the nighttime hours and would cause false alarms.

As mentioned earlier, the main drawback to IR Cameras is the purchase price. Since IR Camera technology is more advanced when compared with other surveillance equipment it is more costly when compared to other camera systems. In most cases it may be more cost effective to use a typical video surveillance camera with adequate lighting in lieu of using a more expensive IR camera. There are pros and cons for each system that must be analyzed by the security system designer so the most cost effective and efficient system can be installed.

Typically IR Cameras are not built for exterior applications so it is important to include weather resistant, protective housing for the cameras when estimating the system cost. Many such enclosures are offered by the manufacturer of the IR camera and can be custom made for any sort of application. Although the cost is high it is still a valuable piece of equipment and was used on multiple case study bridges detailed later on in this report.

#### 4.2.3.2 Video Surveillance

Video surveillance equipment is viable for monitoring bridge activity during the daytime or if the bridge will be adequately lit during the nighttime hours. It is important to know the technical abilities required of the camera and choose a camera that will meet or exceed the expectations. The price for a common video surveillance camera is quite low when compared with the IR Camera and it may prove appropriate to place multiple cameras around the site.

Some cameras have the ability to change from infrared to visible light depending on the level of light in its vicinity. These cameras may be a more economical decision than buying them both separately. There are several manufacturers of cameras for adverse exterior conditions that range in ability and price. It is important to work with the manufacturer to select the

appropriate camera for the bridge site in question. Much like the IR camera, the video surveillance camera must be located in a tamper resistant housing.

#### 4.2.3.3 Heat Detector

There are several different types of heat detectors that can be selected for bridge security. The two most common heat detectors that are commercially available are the fixed temperature and the rate of rise heat detectors. The fixed temperature heat detector is set to sound an alarm once a predetermined temperature has been reached. A rate of rise heat detector will set off any alarm once a certain rate of temperature gain has been reached. Both the predetermined temperature and rate of rise can be adjusted to practical levels determined. These settings are relatively the same as the thresholds for an IR camera as mentioned earlier.

It should be noted that the rate of rise heat detector may be more vulnerable to false alarms within the given environment. The covered bridges may be susceptible to sudden increases in temperatures in short periods of time that could exceed the rate at which the heat detector is programmed, such as being warmed by the sun, a piece of machinery running next to bridges still open to traffic, etc. With these conditions being present on most covered bridges it is important to place heat detectors out of direct sunlight. Some possible places to put these devices would be underneath the wooden deck or underneath the rafters on the top portion of the bridge.

#### 4.2.3.4 Smoke Detector

A smoke detector may assist with the fire protection coverage on a covered bridge; however, it may have a higher source of false alarms because the smoke detector will have to be placed within the covered bridge to be effective and will be vulnerable to dust and other debris coming in contact with it and causing a false alarm or obstructing the sensors and decreasing its functionality given these negative aspects of the smoke detector, it will more than likely be considered obsolete on most bridge applications unless the proper measures are taken to ensure that it will be free from dirt and other debris while still having the ability to monitor smoke levels. Taking the necessary steps to ensure that these conditions are met with the



smoke detector may not be the most cost effective way to protect the bridge.

#### 4.2.3.5 Flame Detector

A flame detector may be one of the more important pieces of equipment in a set-up for security of covered bridges. The flame detector may be placed within the bridge interior where it will be able to view a large portion of the bridge. If necessary, multiple flame detectors may be used together in a system in order to optimize coverage of the bridge. Most flame detectors have a mechanism that significantly reduces false alarms but this will have to be verified with the manufacturer of that specific flame detector. There are also some companies that sell IR Cameras that allow the camera to perform functions similar to a flame detector but these devices are usually more expensive than the two sold independently.

A flame detector will set off an alarm whenever a certain temperature is reached that surpasses the predetermined threshold that is decided upon by the system designer. As mentioned earlier, there are multiple types of flame detectors and many have several different methods of discriminating between true and false positives. It is important to realize when deciding upon a flame detector to use that the purchase of a cheap detector may develop multiple problems with detection and the instigation of false positives.

#### 4.2.3.6 Fiber Optic Sensor

Fiber optic sensors may be used to measure rotation, acceleration, electric and magnetic field measurement, temperature, pressure, acoustics, vibration, linear and angular position, strain, humidity, viscosity, chemical measurement, and a host of other sensor applications not mentioned here. The fiber optic sensors typically used for bridge security measure changes in temperature along the length of the bridge. The main advantage of these sensors is that they are lightweight, small in size, passive, resistant to electromagnetic interference, highly sensitive, bandwidth size, and are durable.

There are many different types of fiber optic cables that vary in price and it is important to choose a cable that can survive in the adverse exterior conditions where many of the bridges

are located. The cost of fiber optic cables can be very cheap when compared to other equipment and the cost continues to go down as the technology improves.

#### 4.2.4 Defend Equipment

##### 4.2.4.1 Fire Hydrant

One portion of fire protection that could easily be overlooked is how the fire will be extinguished. Fire trucks can store their own water and some even have the capability of pumping water from sources such as nearby rivers and lakes. However, in some cases the water source is too far below the elevation of the road to allow pumping. In this case, an additional pump at the water may be necessary to aid the fire truck in pumping the water up to the road elevation. It is important to know the limitations and abilities of the fire department that provides service to the covered bridge of interest.

If a municipal source exists near the structure there should be fire hydrants located on both sides of the bridge placed at a far enough standoff distance that heat from a bridge fire would not impede fire fighters hooking up hoses. If it is uneconomical to connect to the municipal water source due to the isolated condition of the covered bridge it may be plausible to install a dry fire hydrant by connection to a water source nearby as mentioned above.

##### 4.2.4.2 Sprinkler System

If any sort of considerable fire has been established before the fire department can arrive at the bridge the center of the bridge may be inaccessible to fire personnel. This is a major problem for the structural integrity of the bridge since this is where the largest forces occur on the bridge. This problem can be solved by the installation of sprinkler systems within the center portion of the bridge or along the entire length of the bridge. It is essential that the sprinkler system selected be a dry pipe system so that freezing and bursting pipes do not become a problem during inclement weather. A dry pipe system has no water in the pipes until a sprinkler head is set-off at which point water enters the system and extinguishes the flames.

The first question the bridge owner would ask when discussing the possibility of installing a sprinkler system is the aesthetic impact on the bridge. Since most sprinkler systems are relatively bulky and unattractive it is important to place them in inconspicuous areas that are not seen by the public. The most economical and effective areas to place the sprinkler systems would be running underneath the bridge with the flow pointing upwards towards the bridge deck as well as above the roofing members with the direction of the flow pointing down and to the sides. This will provide the greatest bridge coverage for most bridge applications.

There are specific guidelines that must be followed when installing systems on historic sites in order to not detract from the historic significance of the site and the possibility of losing its ability to be placed on the Register of Historic Places. Therefore, careful selection of a respectable construction company is of utmost importance for the installation of the sprinkler system.

#### 4.2.4.3 Fire Retardant Material (Hering)

Achim Hering gives us insight on fire retardant materials in “The Proof Is in the Fire.” One of the most common types of security measures taken by covered bridge owners is to increase the fire resistance of the bridge. This is due to the cost efficiency of the material when compared to the level of protection added to the bridge. This can come in the form of some sort of coating such as intumescent coating or using fire retardant wood when rehabilitating or repairing a bridge. This falls under the category of structural strengthening and will help the bridge stay structurally sound during the course of a fire before it is able to be extinguished. Using fire retardant materials should not be seen as a final solution for bridge security because it does not stop the initiation of a fire but does slow the progress of a fire such that major damage can be avoided. The application of a fire retardant material to structural elements that are essential to the survival to the bridge is one of the most desired actions with bridge security related to fires.

Many of the lighter bridge elements such as shingles, siding, as well as any thinner wooden framing should be considered when deciding what needs to be treated with fire retardant materials. These thinner pieces can be ignited much easier than the larger structural members such as the bridge deck. These thinner bridge elements can be the fuel to starting the larger members and cause serious structural damage in the case of a long burning fire. Although it may be more economical and efficient to make the thinner elements fire retardant it is not uncommon to make the entire structure fire retardant for an added level of fire safety. The cost should be weighed against the advantage of such an extensive procedure.

#### 4.2.4.3.1 Intumescent Coating

One of the more common fire retardant materials used for covered bridges is intumescent coating. Intumescent coating is a thin layer of material that is very similar to paint in method of application as well as aesthetics and texture. It can come in a variety of colors including clear and semi-clear. There are multiple manufacturers of intumescent coatings as well as similar materials that can match the exact color scheme of any bridge so this coating can be applied to existing bridges or new bridges.

The way intumescent coating works is by swelling when exposed to a certain level of heat that would be seen during the course of a fire. The chemically bound water in the coating absorbs heat making it ideal for fireproofing applications. Intumescent Coatings are used to keep the fire in the location of its origin instead of spreading. This type of coating will only become active after exposed to heat. Although the coating of essential structural members is the most important it is also beneficial to coat the entire bridge including siding, roofing, and all framing.

Although this is a very effective method of making a structure more fire resistant it still has several drawbacks that must be considered for optimum protection. Much like any coating, intumescent coating will wear down and become less effective over time and will need touch ups every few years and possibly an entirely new coat after multiple touch ups. These times are dependent on the conditions at the bridge site including humidity, direct sunlight, and

temperature changes. Different manufacturers will have different materials that will be adaptable to different conditions so it is important to choose the correct coating for an exact bridge location.

#### 4.2.4.3.2 Fire Retardant Wood (Durfee)

Robert Durfee has an extensive section on Fire Retardant Wood in his article “Vermont’s Covered Bridges.” Fire retardant wood is created by pressure treating the wood with a fire retardant chemical. There are multiple manufacturers of fire retardant materials that use different chemicals and have differing levels of fire resistance. Most fire retardant woods are designed to not light on fire even with direct contact with a flame or the fire will not spread after it is initially lit.

A major drawback to using fire retardant wood is the decrease in the structural strength of the member by up to 10 to 20% depending on the exact type of chemical used. This can become a major issue if fire retardant wood is used on structural members such as the bridge deck since the members may need to be larger since they will have decreased strength. Much like the intumescent coating there is a decline in the effectiveness of fire retardant wood that is accelerated from being in a harsh, exterior location. This decline in effectiveness can be slowed substantially by painting the wood soon after installing it.

### 4.3 Pole Placement

It will be required for most security systems, especially those involving cameras, to have a pole or pedestal of some kind for placement of the necessary security monitoring hardware. Below are some of the key factors to consider when selecting a pole type and location.

#### 4.3.1 Aesthetics

The pole placement will ultimately come down to the decision of the city or owner of the bridge. The most important factor influencing the final placement of the pole will be the aesthetic impact on area surrounding the bridge. Since covered bridges can be a major

source of tourism for smaller towns around the United States it is important that the security systems installed do not draw attention away from the bridge and the surrounding landscape. Depending on the landscape and surrounding this may be detrimental to the effectiveness of the security system since this usually requires the pole be placed a large distance away from the bridge. An ideal situation at the bridge location would be a preexisting pole such as a light pole or power line pole that, upon approved of the owner, could double as the mounting pole.

The type of material that is used for the pole is mostly an aesthetic decision. There are several different types of materials that can be used for the pole such as metal, concrete, or wood. In order to blend in with the surrounding area it would suggested that a survey is taken of what is around the possible pole location to see if there are other light poles or electrical poles within eye sight. If there are other poles in the surrounding area it would be preferable to use the same type of material and pole height to let the security pole blend into its surroundings.

#### *4.3.2 Line of Site*

Even if there is a pole within a reasonable distance from the bridge it must be guaranteed that there is a direct line of sight to both the front and rear entrances to the bridge to allow the system to be as efficient as possible. Even if there is a direct line of sight at the moment that the security system is enabled it is important to look for possible obstructions in the future such as trees or other vegetation that could have the potential to grow or move into the direct line of sight. Any potential problems should be dealt with as soon as possible to avoid costly problems in the future.

It may be possible to only allow direct line of site to one entrance of the bridge due to environmental constraints. If the designer has the ability to use a pole facing towards either entrance of the bridge there are many criteria that must be considered. If the bridge is closed to vehicle traffic then the entrance that will see the greatest amount of pedestrians should be considered to allow for the great amount of security on the bridge. The ease of connecting to

electrical power should be highly considered if electronic equipment will be used in the security system.

#### *4.3.3 Functionality*

There are multiple problems with placing the pole at a significant distance from the bridge and there must be a compromise between aesthetics and functionality in order to make the pole as practical as possible while still keeping its presence as benign as possible. The two major problems with placing the pole at a significant distance from the bridge come from the effectiveness of the cameras and problems associated with running the wire over long distances. Both of these problems can be solved by using more sophisticated equipment but that directly correlates to an increased cost for the project.

There are differing ranges that a camera is still effective in generating a clear and usable image by the user. These ranges will obviously change with differing manufacturers and cameras so it is important to read all the specifications for the camera that is being purchased and ensuring that all the requirements for a certain bridge are met by the camera selected. This is applicable to all cameras used on the bridge including infrared or optical cameras.

The other problem that results from a greater pole distance is friction loss within the wires that must be run from the pole to the bridge. Although this particular problem will not usually be a critical problem with the security system design it is something that needs to be considered before placed in the field to ensure that the proper power is reaching the systems so that it operates as expected and does result in maintenance issue down the road. If there are major problems with power loss across the wire between the bridge and the pole there are several different solutions that could be applicable depending on the amount of power loss. One solution could be to use a wire with a higher conductivity so there would be less friction loss. Another solution could be to use a higher source of power that will overcompensate for the loss across the wire. These are additional tradeoffs that must also be considered in the budget.

It may be desirable to the owner to use the pole for other functions outside of security reasons. These other functions could include placing a street light on the top of the pole to provide lighting for the surrounding area. This could also be considered a security device since well-lit areas are less likely to have trespassers that could potentially cause harm to the bridge. It is important that the street light does not cause the area to be over lit which could cause light pollution and take away from the aesthetic value of the surrounding area.

#### **4.4 Enclosure Selection**

Depending on the functionality of the security system, there will be varying amounts and types of equipment that, due to their design, construction, and cost need to be housed in a secure location that will also protect them from outside elements. There are several ways to do this, and much like the selection of all the other aforementioned components, there are several factors that should be considered in the selection of the appropriate enclosure.

##### *4.4.1 Types of Enclosures*

###### 4.4.1.1 Standard Box

A metal box will prove to be efficient for most bridge sites as many pieces of electrical equipment require little components for power and storage of data. If cameras are used as part of the integrated security system on the bridge site a small box could easily fit on the pole itself where all the cameras are located. If a pole is not available, a box may be positioned on some sort of pedestal to allow the box to be safely lifted off the ground as to deter any water, insects, or animals from attempting to enter the box.

###### 4.4.1.2 NEMA Enclosures

The writers of this report suggest that the box meets a certain standard set by National Electrical Manufacturer's Association (NEMA) and for most applications with these systems the owner should require at least a NEMA 4, 4X, 6, 6P. The technical explanations of the exact NEMA standards are as follows:



Type 4 - Computer enclosures constructed for either indoor or outdoor use to provide a degree of protection to personnel against incidental contact with the enclosed equipment; to provide a degree of protection against falling dirt, rain, sleet, snow, windblown dust, splashing water, and hose-directed water; and that will be undamaged by the external formation of ice on the enclosure.

Type 4X - protection unit constructed for either indoor or outdoor use to provide a degree of protection to personnel against incidental contact with the enclosed equipment; to provide a degree of protection against falling dirt, rain, sleet, snow, windblown dust, splashing water, hose-directed water, and corrosion; and that will be undamaged by the external formation of ice on the enclosure.

Type 6 - PC Enclosures constructed for either indoor or outdoor use to provide a degree of protection to personnel against incidental contact with the enclosed equipment; to provide a degree of protection against falling dirt; against hose-directed water and the entry of water during occasional temporary submersion at a limited depth; and that will be undamaged by the external formation of ice on the enclosure.

Type 6P - cabinet constructed for either indoor or outdoor use to provide a degree of protection to personnel against incidental contact with the enclosed equipment; to provide a degree of protection against falling dirt; against hose-directed water and the entry of water during prolonged submersion at a limited depth; and that will be undamaged by the external formation of ice on the enclosure.

For most scenarios a NEMA 4 enclosure will protect the electrical components against the elements since submersion under water will not applicable to most bridge situations and the added cost of this protection will not be required or warranted. If water coming from multiple directions is a problem for a bridge then NEMA 4X should be considered to protect the electrical components. There is a price increase in the protection offered by the NEMA

4X but the added protection is worth the safety of the electrical components within the box.

#### 4.4.1.3 Structure

Some bridge locations will already have a small mechanical shed or other enclosed structure on site. This could prove to be advantageous for the security system designer for its ability to house the mechanical equipment that is required for running a security system. Depending on the size and scope of the security system to be installed it may not be economically viable to construct a new structure on the bridge site to house the mechanical equipment when compared to a box that could be attached to a pole or pedestal as mentioned in the earlier section

#### 4.4.2 Aesthetics

The selection of the enclosure to house all of the electrical components of the security system is comparable to the selection of the pole. The box must not have a large aesthetic impact on the surrounding area but must maintain functionality. Most box set ups that are available to the owner will be constructed of metal and will have a grey or metal color to them. It is possible, and in many applications preferred, to paint the box to match the surrounding area.

#### 4.4.3 Functionality

Once the design team has decided upon the exact NEMA type of enclosure that will be used for the project it is important to decide on the exact dimensions of the box that will be used. This can be accomplished by taking all the equipment that will be placed inside the box such as modems, computers, power strips, and any other sensitive equipment that needs to be secured in a weather tight enclosure. Once you have a list of all the equipment that needs to fit into the box it is important to draw a schematic of how everything will fit. Once you have a rough schematic it should be taken into consideration how many outlets you will need to power all of the equipment and exactly what type of power strip you will be using. Once you have all of this information you should have a rough idea of the size of your box. It is important to order a box that is larger than exactly what you need for minor equipment changes, cords, and future expansion.

It is important to understand the heat that will be generated from the electrical devices within the box that will be exaggerated by the temperature outside of the box in the summer. The temperature within the box can easily become hot enough to overheat the electrical components and shut off the entire security system. Purchasing a box that has a fan or louvers to allow air circulation will add cost to the project but will allow the security system to operate through even the hottest months. After market fans and louvers are available to install on boxes that do not have adequate ventilation. It is essential that any openings in the box protect the components inside from water or insects entering and potentially destroying the electrical components.

#### **4.5 Power Considerations**

The remote locations of many covered bridges within the United States often make it difficult and/or expensive to gain access to electricity to power the security. The distance between the closest grid power and the location of the bridge may sometimes be so great that running a power line to the bridge is not cost effective. If grid power is not an economical option, there are different types and combinations of renewable energy sources that may meet the needs of the system. Renewable Energy will be discussed in full detail later on this section of the report.

##### *4.5.1 Grid Power*

If a hook up to grid power is readily available and economically viable it will typically be the best choice since it will be the most dependable source of electricity. It is important to have a constant source of power with any security system to ensure that it works properly at all times. The only problem with grid power is the reoccurring cost from the local electric company for using their services. Given the draw from a typical security system is relatively small, the charges will also be minimal; however, it is only prudent to consider this in the budget.

#### 4.5.2 Renewable Energy

It is important to think about using multiple sources of renewable energy when setting up this type of system because any one source will not be consistent over a long period of time. Wind power only works when a substantial wind is occurring and solar power will only generate electricity during daylight hours, with energy output varying with the intensity of the sunlight. By using both systems you will increase the chances that one of the power supplies will be generating enough electricity for the security system. Batteries must be used with these power sources if there is not grid power to store electricity for when power is not sufficiently being generated. It is possible however that one source of power will suffice if the draw from an individual security system is relatively small and the battery bank is relatively large and can provide an adequate duration of reserve power.

It should be mentioned at this point that using renewable energy to power a security system is a large undertaking and should be thoroughly thought about and discussed before design. Compared to a direct city link for electricity, a renewable energy system will require a lot more planning, maintenance, upfront cost, and patience. This fee will not occur with the use of renewable energy sources but a city hook-up will not have the large upfront cost associated with setting up a renewable energy system. The BEC faced several difficulties while designing and installing the alternative energy system at the Hogback Bridge as discussed further in the Madison County Project portion of this report.

Some systems may elect to use both grid power as well as a renewable energy system. A system of this type will use renewable energy whenever it is generated and used the grid as a backup if the renewable energy sources stop producing energy. By using this type of system you can also utilize the energy that is generated but not stored or used. Some electric companies will allow you to generate electricity for them and will pay you incentives to do so. These incentives have the possibility of paying back the fee associated with using the grid power and possibly even pay the security system designer over time. This incentive system is something that must be talked about beforehand with the power company.

There are multiple types of renewable energy systems that currently exist and several other sources that are on the horizon. Although there are multiple sources of alternative energy there are only a few that will be useful at most covered bridges sites given their isolated locations and natural surroundings. The only sources of alternative energy that will be discussed within this report are wind and solar power since these are the two sources that will likely be present at most, if not all, covered bridge sites. If a security system designer has the capacity and ability to harness other sources of renewable energy available at the bridge site there should not be any hesitation to take advantage of it just because it is not discussed in this report. As mentioned earlier with other decisions, this report is not intended to be all encompassing and there are multiple alterations for all portions of a security system.

#### 4.5.2.1 Wind

Blades of a wind turbine harness energy from the wind and turn it into electricity through the movement of the blades. Ideally, a wind turbine should be placed in an area that has constant, non-turbulent wind, and it is recommended that the wind turbine be placed at least 30 feet above the ground and 300 feet away from all obstructions that could cause turbulent wind such as structures or trees. These distances are only recommendations and may be shortened but optimal performance of your wind energy system will be at distances that equal or exceed these recommendations. Different companies may have different recommendations for the placement of their particular wind turbines and it is important to follow them as closely as possible in order to get maximum efficiency out of the equipment.

In general, the more power required from a wind turbine can produce the greater the blade diameter. The blade diameter often becomes a limiting factor when designing a hybrid energy source depending on what is allowed by city ordinances and historic limitations in the area that the security system will be installed. It is important to realize that the wind turbine will be placed within close proximity to a covered bridge that is a draw for tourism and the local economy so care must be taken to not detract from the aesthetics of the surrounding area.

When sizing the wind turbine for a particular security system it is important to realize that the rated output for the turbine is for the optimum wind speed, which will not be the average wind speed in many instances. These speeds can meet or exceed 20-30 miles per hour with most types of wind turbines, which is not a constant wind speed in most areas. It is important to look at the wind speed to power output graph that is supplied with most turbines in order to choose the correct equipment that will produce the proper power output at average wind speeds at the bridge site. Figure 7 shows a wind speed to power output graph for a 600 watt wind turbine and shows that it will only produce 600 watts of power if the wind speed meets or exceeds 26.4 mph (12 m/s). Average wind speeds are roughly 11 mph (5 m/s) on the coasts of the United States and 17 mph (7.5 m/s) in the Midwest.

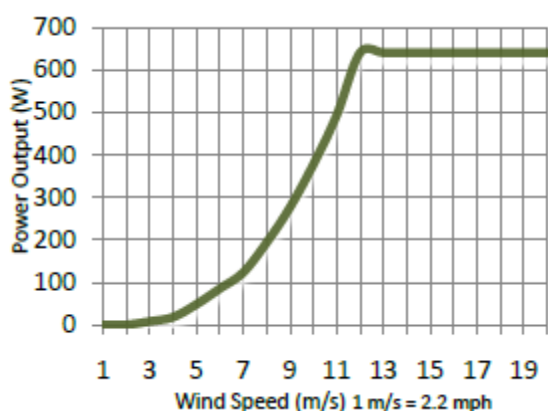

Source: Urban Green Energy 600 watt Wind Turbine Specifications

**Figure 7: Wind Speed to Power Output Graph for 600 watt Wind Turbine**

For systems with lower power requirements, 100-10,000 watts, there are two main types of wind turbines suitable for these applications: the horizontal axis wind turbine and the vertical axis wind turbine. Each type of wind turbine has its distinct advantages and disadvantages and there must be a benefit/cost analysis done to consider price, efficiency, and power output for the type of power output needed for a particular security system. The vertical axis turbines are well suited for smaller applications such as a security system and can survive wind gusts better than most horizontal wind turbines. It is important to discuss with the manufacturer the exact requirements needed for the security system and the environment that it will be installed in.

#### 4.5.2.2 Solar

Solar panels harness the sun's energy and efficiently convert it to electricity. Solar panels continue to become more efficient as the technology improves making them smaller and more efficient; that said, size is still a main factor in the selection of a solar power system. Current technology allows 10 watts per square foot of solar panel according to top solar companies available for distribution in the United States ("Solar & Wind Energy Calculations: The (very) Basics." 2011). There will be panels that will give you more or less wattage per square foot depending on price and the advancements in technology within the company. It is important to realize that an increase in efficiency will directly relate to an increase in price.

Although solar power can be an efficient source of renewable energy it is still temperamental and should not be thought of as a constant source of power. Since most security systems will need to be functional at all hours of the day it is essential that there is a constant source of power day and night. Therefore, since solar power is only available during the day it is essential to incorporate an adequate sized battery bank and potentially coupling it with wind power or grid power to allow for uninterrupted power day and night.

#### 4.5.2.3 Battery Bank

Batteries are important for any renewable power source system for moments where the desired medium is not enough to generate power such as it being nighttime for solar panels or not enough wind for the wind turbines. In order to design the proper battery bank for your system it is important to know the power draw of your security system at peak performance, average hours of sunlight in your area, and the average wind speed in your area. Most renewable energy companies will be able to help you estimate the natural conditions at the bridge site depending on which part of the country the bridge is located. There are also multiple resources online with this information.

There are batteries that are designed specifically for renewable energy sources but marine or

deep cycle batteries are also quite effective if designed and sized properly. Since the system will create a steady draw from the batteries even though the batteries will not get a consistent charge it must ensure that the batteries will not fall below 50% of their amp hour capacity so no damage occurs to the batteries. Once batteries have fallen below a certain percentage of their amp hours they may not be able to become fully charged with the aid of a renewable energy system.

#### 4.5.2.4 Inverter

The inverter converts the DC power created by the renewable energy sources into usable AC power. There are two main types of inverters for this application the pure sine wave and a modified sine wave. A modified sine wave inverter is cheaper and has applications in other systems but does not produce the proper results for the security system being installed. Pure sine wave inverters are more expensive, but are the appropriate choice for this application. Much like the solar panels and wind turbines, the inverter is not 100% efficient so it will be required to increase the power supply to compensate for this loss across the inverter. It is important to do research on different companies that produce pure sine wave inverters and purchase one that meets or exceeds the expectations for your particular security system.

#### 4.5.2.5 Controller

A renewable energy source will continue to charge the batteries indiscriminately if left unattended which will overcharge the batteries and potentially damage them if the charge into the batteries is greater than the draw out of them. Therefore, use of a charge controller is necessary to monitor the level of charge of the battery bank and manipulate the level of charge to the battery as needed. There are as many types of controllers as there are renewable power sources so it is essential that a manufacturer's specification meet or exceed the requirements of the power system installed.



## CHAPTER 5 SET-UP

There are several important steps associated with the set-up of the security system to ensure that it is aesthetically pleasing and as functional as possible. Although many of the major pieces of equipment have been discussed in great detail in previous chapters of this report it is important to have an understanding of all auxiliary equipment that is required to make the entire system functional. These materials include the type of conduit, wires, encasements, and the equipment to attach the box to the pole. There may be more equipment required for a particular security system depending on the location and type of system that will be installed. It is important to have the understanding that if the security system does not survive the vandalism or arson then it has failed at its task and is not worth the funds to install it in the first place. The safety of the security system must be considered just as highly as the bridge itself when the system is installed for proper operation. All equipment should be tamper proof and not easily disconnected by vandals.

### 5.1 Conduit

To prolong the life of all wires and equipment it is important to use conduit to run all wires from the pole to the bridge. There are several types of conduit that could be used including PVC, metal, or plastic. The design team should run an economical analysis deciding how vulnerable the wires are underground and how much each type of conduit available costs. It is important to choose a safe option that will adequately protect all the equipment but it isn't necessary to always choose the strongest alternative. All conduit should meet or exceed all fire and electrical codes in the area of installation in order to effectively guard against fire or shorting of wires in the conduit itself. The conduit should also be strong enough to protect against animals or insects penetrating the conduit and destroying the wiring.

### 5.2 Wiring

There are a variety of sizes and types of wires that range in price and functionality. These two main properties of wire are two of the biggest decisions when deciding on what type of wire should be used for any particular piece of equipment. Some equipment will have a

minimum requirement for wire size in order to reduce resistance and improve the functionality of the piece of equipment itself. It can be seen by Figure 8 that as the gauge number of wire decreases the diameter increases and the resistance decreases. A decrease in wire gauge will also lead to an increase in price per length, so it is not always practical to use the smallest gauge wire to increase functionality unless it is economically viable. If there is considerable distance between the equipment and where it must be powered from then a decrease in wire size may be required in order to reach an acceptable level of functionality from the piece of equipment.

AWG	Diam mm	Sect. mm <sup>2</sup>	Resist. ohm/m	AWG	Diam mm	Sect. mm <sup>2</sup>	Resist. ohm/m
0000	11.7	107,0	0.000161	19	0,91	0,6530	0.0264
000	10.4	85.0	0.000203	20	0,81	0,5190	0.0333
00	9.26	67.4	0.000256	21	0,72	0,4120	0.0420
0	8.25	53.5	0.000323	22	0,64	0,3250	0.0530
1	7,35	42,4	0.000407	23	0,57	0,2590	0.0668
2	6,54	33,6	0.000513	24	0,51	0,2050	0.0842
3	5,83	26,7	0.000647	25	0,45	0,1630	0.106
4	5,19	21,2	0.000815	26	0,40	0,1280	0.134
5	4,62	16,8	0.00103	27	0,36	0,1020	0.169
6	4,11	13,3	0.00130	28	0,32	0,0804	0.213
7	3,67	10,6	0.00163	29	0,29	0,0646	0.268
8	3,26	8,35	0.00206	30	0,25	0,0503	0.339
9	2,91	6,62	0.00260	31	0,23	0,0415	0.427
10	2,59	5,27	0.00328	32	0,20	0,0314	0.538
11	2,30	4,15	0.00413	33	0,18	0,0254	0.679
12	2,05	3,31	0.00521	34	0,16	0,0201	0.856
13	1,83	2,63	0.00657	35	0,14	0,0154	1.08
14	1,63	2,08	0.00829	36	0,13	0,0133	1.36
15	1,45	1,65	0.0104	37	0,11	0,0095	1.72
16	1,29	1,31	0.0132	38	0,10	0,0078	2.16
17	1,15	1,04	0.0166	39	0,09	0,0064	2.73
18	1,02	0,82	0.0210	40	0,08	0,0050	3.44

Resistance Cu @ 20°C

Source: [http://tk5ep.free.fr/tech/awg/en/awg\\_g.php](http://tk5ep.free.fr/tech/awg/en/awg_g.php)

**Figure 8: AWG Chart for Diameter, Area, and Resistance**

Conduit can be easily used for running wire for certain applications such as underground or up a pole but it may be difficult to use conduit within the bridge structure itself. All wire that

is ran without conduit should have a covering that can ensure proper protection. Within the bridge itself there may be the possible threat of insects and small animals such as rats, birds, and squirrels so it is essential that all wiring be adequately covered to ensure that the wildlife will not be able to penetrate the coverings.

### **5.3 Attachment Devices**

All equipment must be attached to either the bridge or other surrounding structures including poles or other structures. It is essential that all equipment is attached as securely as possible with as minimal of disturbance as possible; this is especially true within the bridge structure itself. Many covered bridges have existed for over 100 years and it is critical that the security system being installed does not change the original design or construction of the covered bridge to preserve the historic significance of the bridge. If large alterations are completed bridge it is possible that the bridge may not be eligible to be placed on the Register of Historic Places as mentioned earlier on in this report. Whenever screws, or any piece of equipment that will penetrate into the existing bridge, are required it is important to use the smallest diameter of screw as possible to minimize the permanent damage to the bridge.

### **5.4 Encasements**

When ordering the equipment for a particular security system it is important to notice the ability of the equipment to handle an outdoor atmosphere. Some types of equipment will be designated for indoor applications unless certain guidelines are taken such as the use of watertight enclosures that can be purchased separately. This is an often overlooked part of the security system but is important to the longevity of the system. Some proprietary systems will have encasings for their products to secure them for exterior exposure while others may require the use of another system rather it be from another manufacturer or another proprietary encasement system.

Some encasements may also be used in certain applications in order to increase aesthetic value of the equipment. These types of encasements may appear in the form as a wooden

box around the equipment in order to give the appearance of a bird house as seen in Figure 9. By using the same wood as the surrounding bridge members were built with, the flame detector is not as aesthetically distracting as it is without the use of an encasement system. The simple act of painting the existing encasement of equipment to match its surroundings can be beneficial and detract from its aesthetic impact.



**Figure 9: Flame Detector in Covered Bridge without Encasement (top) and With Encasement (Bottom)**

## 5.5 Supplementary Equipment

For any security system involving electronic components it will be required to have supplementary equipment in order for all components to operate efficiently. As mentioned earlier, it is important that someone knowledgeable about security systems, such as an IT professional, is asked to assist in the installation of all electronic equipment. Most electronic equipment will have software that may require manipulation in order to have the most efficiency settings possible. Advanced software options are not included in this report since it is such an ever changing field that will be different every security system that is installed.

### 5.5.1 Communication Devices

It will be desirable for some information recorded at the bridge sites to be sent to a remote destination through the use of communication devices. The information recorded by the monitoring systems will prove to be useless if they cannot be seen by others through remote destinations such as local fire departments or police stations. There are multiple ways of transferring this information to outside sources but for more bridge sites the use of directional antennas to access wireless connections will be the best option. Directional Antennas allow for optimum signal in areas where cellular coverage may be low, which is typical in some isolated covered bridge locations.

### 5.5.2 Storage Devices

It will be important that some data is stored at the bridge site if not all information is sent to a remote location. Depending on the abilities of the communication devices selected it may not be possible to send all information required through wireless sources. A storage device can be as simple as a desktop computer tower or can be much more complex with secure electronic storage cabinets that can be found through multiple manufacturers. It will not be cost effective in most applications to store all information that is recorded at the bridge site but to only record certain information. This can include certain time periods after an alarm has been set-off or during certain times of the day.

### 5.5.3 Software

There are numerous software options when designing a monitoring system on a covered bridge. Some of these software options may be proprietary depending on the piece of monitoring equipment that is selected by the design team. In order for the system to be as effective as possible it is essential that the correct software is chosen and the correct settings are selected within the software. In depth software analysis is not discussed in further detail within this report because of the numerous options available. It is important to work with the manufacturer of the monitoring equipment to allow for optimum efficiency from all equipment within the system.

## CHAPTER 6 TESTING AND MAINTENANCE

Testing is one of the most important aspects of creating an effective security system. All components should be able to fulfill or exceed their individual assignments and the security system as a whole should be able to achieve a high level of security for the bridge as a whole. It should be stated that all fire testing, both in the lab and especially in the field, should be conducted in the safest possible fashion to ensure that there is no damage to any personnel, equipment, or property.

### 6.1 In-house Testing

It is crucial that all individual components of the security system are tested in-house before they are installed and tested at the bridge site. It is easier to trouble shoot equipment that is not working properly in an easily accessible, controlled atmosphere when compared to the bridge site which may have inclement weather and equipment in hard to reach areas. Not only should the individual components be tested individually but the entire systems should be tested all together to ensure that all parts of the system work together to reach the end goal of adequate protection of the bridge site.

### 6.2 In-field Testing

As mentioned before, testing in the field should be conducted in the safety possible fashion. Before creating an open flame around on within the covered bridge itself it is essential that all proper officials are notified to avoid any problems with passer byers from reporting the testing crew. Once all officials have been notified that there will be fires started on the bridge site it is essential that safety precautions such as fire extinguishers and buckets of water are on hand and close by in case something unwanted sets on fire.

Different equipment will have different thresholds at which they will be set off and trip an alarm. A typical fire for a flame detector may be a 1 foot by 1 foot square fire from a distance of 60 to 70 feet. This can easily be done by placing an adequate sized fire proof pan on a cart so it can be pushed across the bridge and ensure that all areas of the bridge are secure.

This is essential to ensure that all cameras and detectors are pointing in the most efficient direction and any adjustments can be made before the system is considered fully operational.

Infrared, or other types, or cameras may be motion detectors or set to a certain temperature threshold. These should be tested at night when they would normally be operational and monitoring the bridge site. A fire may be started at one of the openings or inside the bridge within the line of sight of the cameras to ensure that the entrances of the bridges are secure from trespassers.

### **6.3 Maintenance**

The implementation of these security and monitoring devices should not be considered the end of any security project. Constant monitoring of all equipment and periodic maintenance of both the equipment and the bridge itself are vital to the survival of the system and the bridge. It may be required to renovate the bridge both aesthetically and structurally throughout its life and both of these issues are discussed briefly in the recommendations portion of this report and also in great detail in *Covered Bridge Manual* by Phillip Pierce. Within years or even months a monitoring or security system can prove to be obsolete and will not be able to fulfill its initial requirements.



## CHAPTER 7 CONCLUSION

Covered bridges are an important part of history of the United States and must be maintained for future generations. Unfortunately these bridges are being destroyed at an alarming rate due to arson, vandalism, and neglect. It is essential that covered bridge owners know the importance of maintaining the structural and aesthetic integrity of their bridges. As stated earlier in this report, The Blue Ribbon Panel Workshop for the Federal Perspective of Bridge Security Assessments has decided on five different levels of security to construct an effective defense against unwanted activities. These levels of security include deter, deny, detect, defend, and structural strengthening. The five parts of the security plan proposed by the BRP are equally important if implemented correctly. This report has taken an in depth look at the different security and monitoring equipment that can be used at covered bridge sites.

### 7.1 What These Levels of Bridge Security Hope to Accomplish

Bridge owners that implement the levels of security discussed in this report should not expect their bridges to be indestructible but must realize that this increased level for security will greatly improve the chances that the bridge will survive for generations to come. It is impossible to make a structure perfectly secure but it is the responsibility of the bridge owners to make the structure as secure as possible within the economic and aesthetic limits of the bridge site and the financial situation of the bridge owner. As mentioned numerous times throughout this report it is essential that all levels of bridge security are covered.

### 7.2 Recommendations

Protection against arson and vandalism alone will not ensure the safety and longevity of the Bridges of Madison County. Other preventative measures must be taken as often as possible so the bridges do not succumb to other natural or manmade disasters. There is extensive coverage on the types of preventative measures that should be taken with historic covered bridges in the Federal Highway Administration Covered Bridge Manual published in April 2005 in Chapter 17 “Preserving Existing Covered Bridges”. Topics included in this report are; controlling water runoff, roof & siding protection, foundation support, regular cleaning,

and fire protection. The FHWA report goes into other preventative measures for covered bridges.

When an extensive search for security and monitoring systems on covered bridges through the United States was conducted it was found that the most used type of protection for covered bridges was the use of flame resistant materials. These types of products tend to have a low cost for how effective they can be and may only need maintenance every five to ten years. Most covered bridge owners, especially in the current recession, may not have large sources of funding and a large scale monitoring system may not be financially reasonable. Bridge owners may also have difficulty with the heavy amount of maintenance that may be required for some monitoring or security systems.

### **7.3 Phases of Monitoring or Security System**

There are four important phases of any monitoring or security system that must be thoroughly discussed before any portion of the project begins. For larger bridge owners such as State DOT's or local governments it may be possible for all portions of the monitoring or security system to be completed in house but this may not be possible for smaller bridge owners that do not have the capacity. In order to avoid any problems with the system and ensure that the system is as effective as possible it is essential that all parties involved aware of all arrangements and expectations.

#### *7.3.1 Design*

The design of the monitoring or security system can be very challenging and time consuming depending on the level of security desired and the complexity of the system. If an intricate monitoring system is chosen then there will be software and hardware that will be required and this in itself can become a very expensive and challenging problem. For small bridge owners that do not have the capacity of resources for this level of design then it may be the more appropriate option to outsource the design of the system. This will take responsibility off the bridge owner and allow for a more functional and effective system if it is designed by

a professional within the security field.

### *7.3.2 Installation*

Installation of any security or monitoring system heavily depends on the complexity and scope of the system. If the system is not very technical then the installation could be completed by the bridge owner or someone outside of the security profession. If there are multiple pieces of equipment that much work in unison then it may be in the best interest of the bridge owner to have a third party install all of the equipment. In many cases the company or individual that designs the system may be the same one that installs the system in order to guarantee that it is done correctly.

### *7.3.3 Monitoring*

It does not matter how well any system is designed or installed if there is no one to monitor it and respond to any alarms. In most monitoring applications the system will be overlooked by local authorities to make sure there are not any problems on the bridge and possibly overlooked by the bridge owner or system designer to ensure that the system is working properly at all times and will react to any type of arson or vandalism. It is important to know what the procedure will be if any alarm is set off at the bridge site. If there are cameras at the bridge site it may be possible to remotely view the bridge site after any alarm has been set off to see if it is a false or positive alarm.

### *7.3.4 Maintenance*

The implementation of these security and monitoring devices should not be considered the end of any security project. Periodic maintenance of both the equipment and the bridge itself are vital to the survival of the system and the bridge. It may be required to renovate the bridge both aesthetically and structurally throughout its life and both of these issues are discussed briefly in the recommendations portion of this report and also in great detail in *Covered Bridge Manual* by Phillip Pierce. Within years or even months a monitoring or security system can prove to be obsolete and will not be able to fulfill its initial requirements.

#### 7.4 Future Research Needs

As covered bridge owners continue to install security and monitoring systems it is essential that proper case studies are recorded and updated. Having a well-established record of systems installed in covered bridge environments is essential to other covered bridge owners when making equipment decisions. Having the knowledge of how certain equipment functions in differing conditions helps expand the field of security with respect to covered bridges. It is essential that case studies are continually updated as the system is increased or altered in any way. If a piece of equipment is not working as expected it is important that this is reported in the case study to ensure that bridge owners of future security systems are aware of the shortcomings or limitations of certain equipment.

It is crucial that a database for case studies of security systems for covered bridges is monitored to ensure that all case studies provide an adequate amount of information to be helpful to other bridge owners. An entity, such as the National Historic Covered Bridge Preservation Program for example, must be responsible for this database and edit all case studies for consistency between case studies with an easy to follow format. Not only does the security system need to be adequately described but the situation that the covered bridge is in must also be well documented. This should include such information as location of the bridge with respect to fire departments and local officials, proximity to electrical and water sources, and past problems with arson or vandalism at the bridge site. These case studies, especially in the beginning stages, can also encompass security or monitoring systems on bridges that are similar to covered bridges, which may not be covered. This could include bridges that are at risk of damage from vandalism or arson in isolated locations. Although this manual is intended for historic covered bridges the security systems discussed can be extrapolated to a non-covered bridge or structure.

It is important to constantly monitor new and emerging technologies in the field of monitoring and basic security. Newer equipment will be able to provide a covered bridge with a higher level of security when compared to older and possibly obsolete equipment. As this newer technology continues to enter the market it is essential that this manual, and others

like it, are updated in order to have the most up to date information so that covered bridge owners can be fully aware of what systems are available to them. As technology continues to improve older technologies will reduce in price. Although this cheaper equipment may be attractive to bridge owners it should be noted that this older equipment may not be able to provide the bridge site with the same level of security as newer equipment.

## **CHAPTER 8 MADISON COUNTY PROJECT**

The authors of this report have taken part in a security effort with the County of Madison in Southwestern Iowa to protect five of the six covered bridges in the county. The bridges included within this effort are the Cutler-Donahoe, Hogback, Holliwell, Imes, and Roseman. The Cedar Bridge had a similar security system installed in 2005 by a team consisting of many of the same members, this project will be discussed in some detail and a full report on the entire project is available.

### **8.1 History of the Covered Bridges of Madison County**

At one point in time there were 19 covered bridges in Madison County but due to neglect, vandalism, and inclement weather all but 5 have been destroyed. Although it is unfortunately common for covered bridges to slowly disappear over the years throughout the United States there has been a push in recent years to protect these historic landmarks. The Bridges of Madison County have received heightened awareness due to their increased fame in part from the book in their namesake “The Bridges of Madison County.” This book, written in 1992 by Robert James Waller, was quickly turned into a major motion picture by the same name in 1995 starring Clint Eastwood and Meryl Streep. In 1993 the book received more attention by being named “the book of the year” by Oprah Winfrey, which raised the status of the book to even a higher level.

Unfortunately this fame did not protect the 6 remaining bridges at the time. The Cedar Bridge, the main bridge in “The Bridges of Madison County”, was completely destroyed in 2002 as well as a house that was a major landmark in the book. The Hogback Bridge, which also appears in the book, was set on fire in 2003 but was quickly extinguished by local passer-bys. The Cedar Bridge was completely rebuilt in 2003-2004 and the Hogback Bridge was completely renovated from its damages. These appalling actions caused the County of Madison to team up with Iowa State University’s Bridge Engineering Center and install security measures on the Cedar Bridge to dissuade any further damage to the structure.

Due to the effectiveness of this project in 2005 it was decided in 2010 that surveillance

equipment of a slightly different variety should be implemented on the other 5 bridges based upon how they worked at the Cedar Bridge. The remainder of this Case Study deals exclusively with the project in 2010-2011 and the 5 bridges that it deals with.

## **8.2 Security Equipment Installed**

The same security system was equipped on all five bridges included in this project. There were a total of two cameras and two detectors including an infrared camera, an optical camera, and (2) flame detectors per bridge. In addition to the security equipment there were numerous communication devices installed within an enclosure that allowed for storage or information and remote connection to the surveillance equipment via internet connection. The only difference between systems occurred on the Hogback Bridge where alternative energy sources were used to power the surveillance system. This alternative energy system is discussed in full detail in the Hogback Bridge section of this report.

When compared to the Cedar Bridge Security System installed in 2005 the main difference is the Cedar Bridge was outfitted with fiber optic cables. Due to the problems faced by the design team during installation and during testing of the fiber optic cables it was decided to not use this technology on this security system. Fiber optic cables can prove to be an effective means to protect a covered bridge but there are multiple problems that can arise if not installed and operated correct, as discussed earlier in the equipment portion of this report. This can be said about multiple different equipment options, great care must be taken to ensure that all devices work correctly.

All equipment in the security system for this project was chosen by an information technology professional with experience within the field of security systems. Advanced software settings are not discussed in this report since they are extensive and information involved in programming all equipment to work properly within the system and all proprietary systems will have differing system set-ups. It is important to carefully read all instruction manuals and ensure that all proper settings are chosen while designing a surveillance system so that the optimum capabilities of the system can be obtained. Utilizing

the knowledge of an information technology professional will reduce the design and install time of a security system and is highly recommended by the creators of this manual.

The overall system monitoring is done by a local PC running custom developed software with communications to all devices being made via a local private network router with wireless capabilities, although currently no wireless devices are utilized. External communications are handled by wireless cellular radio. Three subsystems are used by the monitoring system; a Web camera, an IR camera, and UV/IR flame detectors. Utilizing IR camera technology the system will read input from the camera and detect a predetermined maximum range in which a heat signature will cause the system to activate the alert status. The UV/IR flame detector system utilizes signal conditioners which convert voltage into readable digital values. When the flame detector detects the presence of a flame it completes an electrical circuit. The voltage from this circuit is read by the monitoring system and if it falls within the positive voltage range expected will activate the alert status.

When alert status is activated the software monitoring system activates the optical and infrared cameras begin collecting buffered imagery from the camera for a specified timeframe. For this project it was decided to record the optical camera for roughly a minute and a half and the infrared camera for roughly three minutes. Unfortunately this recorded video was not able to be sent wirelessly and had to be retrieved manually by the design team. Also during this time an email message is generated and sent via the wireless cellular radio network connection to identified recipients indicating an alert status has been reached

Both camera images were able to be viewed by anyone who had access to the passwords to enter the system and an internet connection. This was possible due to the Raven Cellular Radio with the assistance of an antenna that was located near the top of the pole pointed directly at a larger cell tower. Since the flame detector did not have any visual component the user was not able to visually see what the detectors were seeing but through the same wireless connection the voltages that the detectors were processing could be viewed. This could assist in seeing what type of fault had occurred and if there was the possibility of a malfunction with one of the detectors.



The optical camera required the use of the Power Injector to use the Ethernet cord to power it. This was then directly connected to the router to give the ability to the use to view the images at any time. The infrared camera was connected to the computer and had its own power cord instead of using the assistance of any other device. As mentioned earlier, the antenna used the raven cellular radio for power and then raven was directly connected to the router as well.

### *8.2.1 Communication Devices*

As mentioned in the previous section there are multiple devices used on this project that were for communication purposes so that personnel could remotely access the surveillance system via internet connection or to enhance the performance of the surveillance equipment. These items include a wireless router, personnel computer, cellular radio, web based remote power switch, signal conditioners, micro servers, power supplies, and power injectors. There are many proprietary systems available for these types of communication devices and the following list of equipment choices are only the selections made the by the BEC design team based on previous projects with similar applications. It is important for any individual design team to choose equipment that can be integrated and that the team feels comfortable using and installing.

#### 8.2.1.1 Wireless Router

An 11G Wireless Nano Router (ESR-1221 EXT) was used in order to extend a wireless signal to the equipment being used on the bridge. This specific type of router has an upgradeable antenna for an increased distance in wifi area.



Source: <http://www.amazon.com/EnGenius-ESR-1221-EXT-Wireless-Ethernet/dp/B0026N3RZ4>

**Figure 10: 11G Wireless Nano Router**

#### 8.2.1.2 Personal Computer

The personal Computer used on this project was the Dell OptiPlex 780 Small Form Factor and is used to monitor the entire system in real time. It is also used to store images that are taken by all cameras during the case of an alarm being set off.



Source: <http://www.dell.com/us/business/p/optiplex-780/pd>

**Figure 11: Dell Optiplex 780 Personal Computer**

#### 8.2.1.3 Cellular Radio

A Raven XE EV-DO Rev is used in addition with an antenna to act as a wireless cellular broadband modem so that all information can be accessed wirelessly from remote locations.



Source: <http://www.mobileprowireless.com/products/AirLink-Raven-XE-EVDO-Rev-A-Verizon-AC-Power-V2226E-VA.html>

**Figure 12: Raven XE EV-DO Rev**

#### 8.2.1.4 Web Based Remote Power Switch

The RPS-ESP-IP Power 9258T with Deltronix Tier 1 Software/Firmware installed was used

to allow personnel to remotely control (4) outlets at one time. This specific type of remote power switch has a timer function allowing a reboot or shut down times without any monitoring by in-field personnel.



Source: <http://www.pacificgeek.com/product.asp?id=37648>

**Figure 13: Web Based Remote Power Switch**

#### 8.2.1.5 Power Injector for Optical Camera

The power injector used for this project was the POE – IPX-INJ-C. The injector delivers both data and electrical power to Ethernet-enabled devices using a single Ethernet cable. This eliminates the need to place the Ethernet-enabled device, such as the optical camera, near an outlet and gives more freedom to the security designer on the placement of the device.



Source: <http://isourcecctv.com/power-over-ethernet-poe-injector.aspx>

**Figure 14: Power Injector for Optical Camera**

### 8.2.1.6 Equipment for Flame Detector

The following equipment was used exclusively for the flame detectors. The flame detectors were set up to alert local officials in Madison County, Iowa whenever a certain temperature was reached on any of the bridges. It is crucial that as few false alerts go out as possible so that local officials do not become complacent and response times increase. In order to reduce the number of false alerts there was equipment that required two different alerts to go off before anything would be sent.

#### 8.2.1.6.1 Signal Conditioners

Two Omega IDRX-PR signal conditioners are used for every flame detector at all bridge sites. There are two per flame detector in order to reduce false positives.



Source: <http://www.omega.com/manuals/manualpdf/M2539.pdf>

**Figure 15: Omega IDRX-PR Signal Conditioner**

#### 8.2.1.6.2 Microserver

The Omega EIS-2B Microserver was used on this project in order to connect the signal conditioners to the wireless connection.



Source: <http://www.omega.com/series/EIS2.htm>

**Figure 16: Omega EIS-2B Microserver**

#### 8.2.1.6.3 Power Supply

A Mean Well MDR-60-24 power supply was used to power both of the flame detectors and a Mean Well MDR-10-5 was used to power the relays in both of the flame detectors.



Source: <http://www.meanwell.com/search/mdr-60/mdr-60-spec.pdf>

**Figure 17: MDR-60-24 Power Supply**



Source: <http://octopart.com/mdr-10-5-mean+well-7856569>

**Figure 18: MDR-10-5 Power Supply**

### 8.2.2 Cameras and Detectors

As mentioned earlier in this section there are a total of two cameras and two detectors including an infrared camera, an optical camera, and (2) flame detectors per bridge site. Figure 19 shows the placement of each piece of equipment that is outside of the box. The antenna, IR camera, optical camera, and enclosure are located on the pole roughly 100 to 150 feet away from the bridge while the flame detectors are located within the bridge itself. The exact placement for each bridge site is seen later in the section when each bridge is discussed individually.

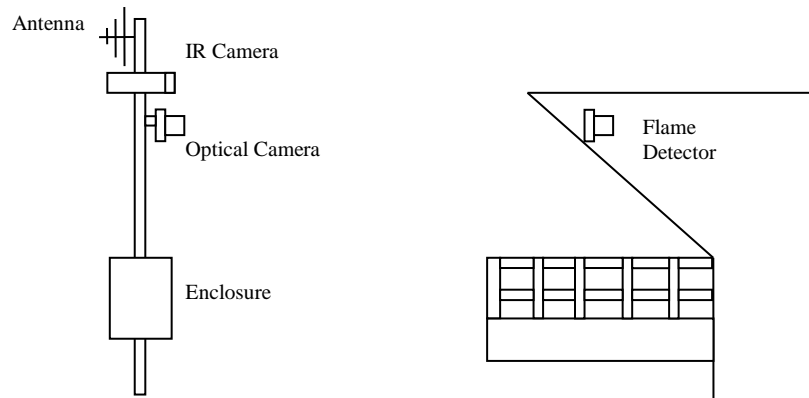

**Figure 19: Cameras, Antenna, and Enclosure Schematic at Bridge Site**

#### 8.2.2.1 Flame Detector

On each of the five bridges in Madison there were two flame detectors installed on either end of the bridge span positioned to cover the largest portion of the bridge possible. There were multiple problems when installing these flame detectors including cross bracing and other structural members interfering with the most ideal line of sight. The final placement of the flame detectors for each bridge is shown later on this section

The flame detector decided upon for this project was the SS4-A Multi-Spectrum Electro-Optical Digital Fire Detector from the Fire Sentry Corporation. This camera senses radiant energy in the ultraviolet (UV), visible, and Wide Band Infrared (IR) spectrums within a 120° of vision. The settings for the flame detectors were set at the 50' to 60' range since most of the bridges are roughly 100' to 120' long from opening to opening.





Source: SS4-A Multi-Spectrum Electro-Optical Digital Fire Detector Manual

**Figure 20: Fire Sentry Corporation Flame Detector**

In order to get the signal from the flame detectors to the box where its conditioners were located a trench had to be dug from the pole to an entry point on the bridge. For most of the bridges it was easiest to trench to the wooden approach span between the abutment and opening of the covered bridge. From the underside of the approach span the wire could be easily positioned through the bridge to the flame detectors without being seen from the bridge deck by a casual tourist. The Cutler-Donahoe Bridge had a newly paved road between the pole and the bridge so directional boring had to be used in order to not disturb the road. The directional bore had minimal disturbance except for entrance and exit points near the pole and the bridge and would be an option for bridge locations where open trenching is unwarranted or undesired.

Since the flame detectors may not be aesthetically pleasing and contrasting to the rest of the bridge it was decided to cover the flame detectors with a wooden case that would take on the appearance of a bird house and be unnoticeable when compared with the white metal camera.

Each camera was also painted brown as not to draw attention to it when seen through the hole in the box. The flame detector with and without the wooden case can be seen in Figure 9.

#### 8.2.2.2 Infrared Camera

For this project there was only one infrared (IR) camera per bridge that was positioned at a certain distance from one bridge entrance, usually within 50-150 feet to nearest entrance of the bridge. The infrared camera used on all five bridges was the IR-TCM 384 HiRes IR Camera Module from Jenoptik. This camera has the ability to produce thermal images in real time of 384 x 288 pixels. An encasing that was provided by Jenoptik was used in order to protect the camera from the elements as well as individuals who would want to damage the camera with projectiles or through other measures. The enclosure for the IR camera had a glass lens that was coated in germanium for optimum performance.



Source: IR-TCM 384 & 640 Manual

**Figure 21: Jenoptik Infrared Camera**

Figure 22 and Figure 23 show the image that the IR camera produces. It produces the date and time as well as the spectrum of temperatures within it's field of view including high and low temperatures. For each of these bridges there is a person standing within the opening of the bridge and the IR camera points out this area of increased temperature when compared to it's surroundings with an arrow and a box with the temperature in it. If these maximum temperatures reach a certain threshold then then IR camera can set off an alarm.



Figure 22: Infrared Camera Image at Cutler-Donahoe Bridge



**Figure 23: Infrared Camera Image at Holliwell Bridge**

### 8.2.2.3 Optical Camera

Directly next to the Infrared Camera there was an Optical Camera placed at every bridge. The Optical Camera provided a similar service as the Infrared Camera except instead of providing images in the infrared light range they provided images in the visual light range. These images were also transmitted in real time over the internet. The camera chosen for this project was the Panasonic BB-HCM735 which is designed for outdoor use so no enclosure was required before installation. This camera has the ability to pan and tilt through remote controls that could be controlled via internet connection. Further specifications about this camera can be seen in Figure 80.



Source: <http://reviewze.com/products/commerical-ip-network-camera-bb-hcm735.html>

**Figure 24: Panasonic Optical Camera**

Figure 25 and Figure 26 show the image that the Panasonic optical camera produces. Compared to the IR camera this image is pretty basic and is used for simple surveillance purposes. When an alarm is set through the IR camera of flame detector the optical camera will record video for a specified amount of time and store it for future viewing so personnel can see what caused the alarm to trigger and to have video evidence of any individuals who may be on the bridge during times when the bridge is closed.



**Figure 25: Optical Camera Image at Cutler-Donahoe**



**Figure 26: Optical Camera Image at Holliwell**

### 8.2.3 Other Equipment

#### 8.2.3.1 Box

The box selection was the same for each bridge. A NEMA 4 box, which is the desired classification of box to be used for most applications as stated earlier in this report, which measures 24”x24”x8” (HxWxD) was used for each bridge. A rough sketch up showed that

there would be considerable room for expansion but after placing everything inside the box in the field it proved to have very little extra room with the inclusion of all wires and power supply cords. This can be seen in Figure 28 with the actual in field layout of the NEMA enclosure. The extra box that is located within the enclosure that is not shown in the sketch is a power switch that is used to remotely switch different equipment on and off in case of a malfunction or a false positive.

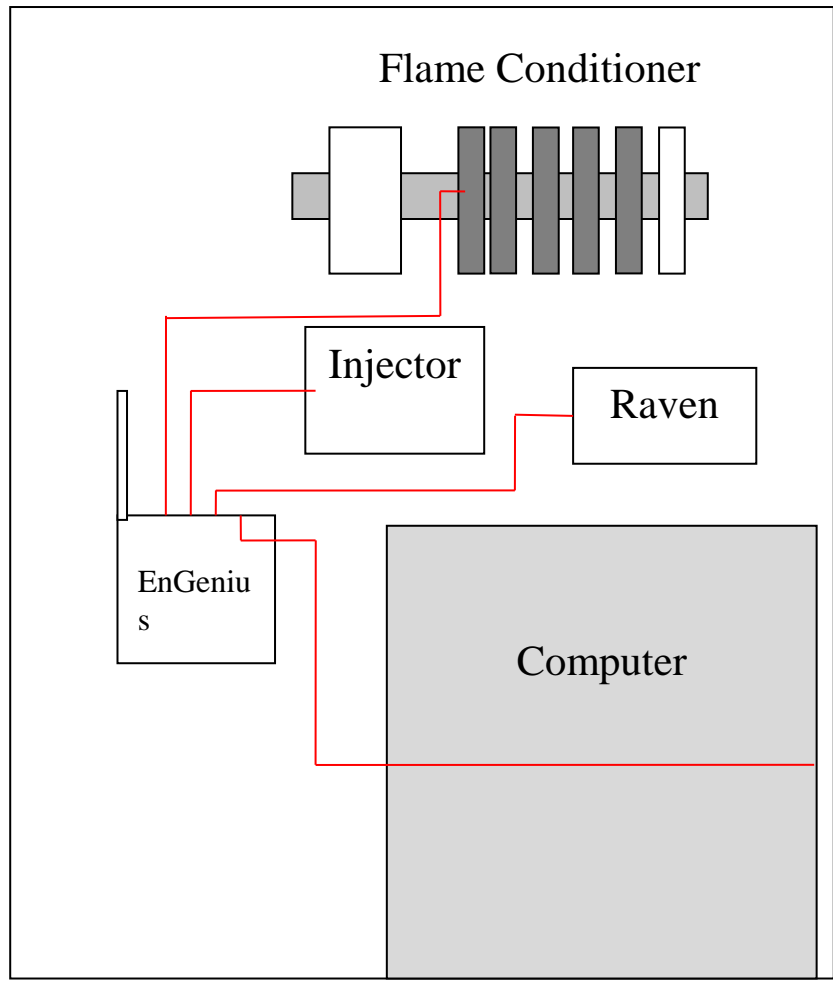

Figure 27: Box Layout for NEMA Enclosure



**Figure 28: Actual Box Layout in Field**

Since the NEMA enclosure was built to be hung on a flat surface brackets had to be made to place the boxes on the pole. These brackets were made with basic  $\frac{1}{4}$ " steel bars that had drilled holes for all lag screws and bolts. At the four points where the box was attached to the brackets an eye bolt was used so aircraft wire could wrap around the pole to provide additional support against the box swaying in the wind.



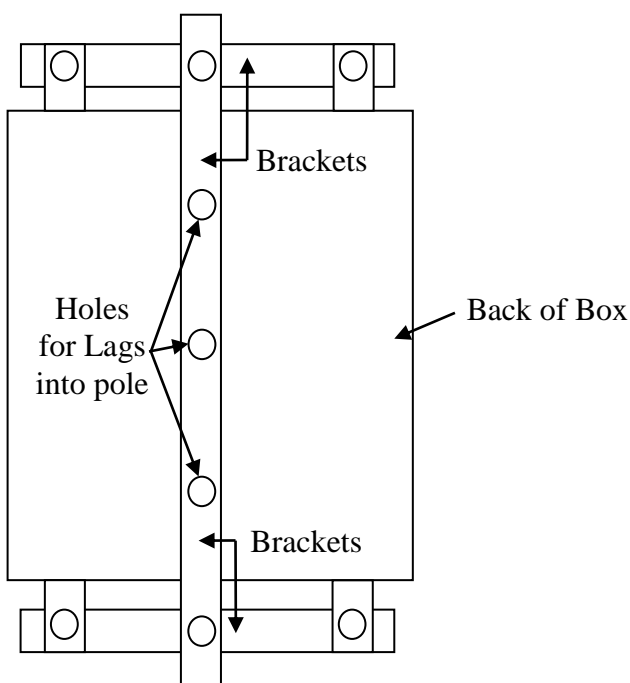

**Figure 29: Brackets for Box to Pole Connection**

### 8.3 Challenges with Each Bridge

#### 8.3.1 Cutler-Donahoe

The biggest obstacle with the Cutler-Donahoe Covered Bridge was its location. The Cutler-Donahoe has been moved from its original location to a city park within the downtown area of Winterset, the county seat of Madison County. Since it was located within a city park it was more difficult to get close to the bridge to complete any necessary construction or attachment of any cameras. A newly poured concrete path between the ideal pole location and the entrance of the bridge caused multiple problems with trenching for the flame detectors on the bridge as well as getting power from the bridge to the pole.

Initially, thoughts were that for obvious security reasons the NEMA enclosures should be installed at a height on the poles such that any vandalism or damage would be difficult to

accomplish. Therefore, for the first bridge we instrumented, the Holliwell Bridge, the enclosure was installed approximately 20ft from the base of the pole. Shortly thereafter, it was determined this was not only not very user friendly, but also not necessary if other precautions were made. On the subsequent bridge, the Cutler-Donahoe Bridge, the NEMA enclosure was set roughly 8 feet off the ground as seen in Figure 30. It was decided later this height was still unnecessary and it is only required to set the enclosures at a chest height level as long as enclosures were properly marked and securely locked. It is the decision of the bridge owner for the mounting height of all equipment. If the bridge site has had problems with vandalism it may be necessary to keep all equipment at a higher level (8 feet or more) to inconvenience any trespassers.

The flame detectors for this particular bridge were required to be placed in the middle of the openings because of the architecture of the bridge. This caused multiple problems since cross members tended to get in the way of a direct line of site for the detectors. Other bridges allowed side mounting of the flame detectors so that cross members and other structural members did not inhibit a direct line of a site and were of optimum efficiency. It is essential when installing all equipment both in the bridge and around the bridge site to balance the aesthetics of the bridge site with the functionality of the equipment.



**Figure 30: Cutler-Donahoe Pole**



**Figure 31: Cutler-Donahoe Flame Detector that is set off**

### 8.3.2 Hogback

The Hogback Covered Bridge proved to be the most difficult bridge out of the five completed on this project. Due to the isolation of this particular bridge it was equivalent in price to run the electric from the local municipality to the bridge site as it would be to set up a renewable energy system that utilized the solar and wind power in the area. Neither the BEC nor the County of Madison had ever tried to develop such a large, stand alone alternate energy system prior to this project so there were initial uncertainties of such an undertaking. After discussion it was decided to use alternative energy sources with the aid of professionals within the industry of renewable energy. As seen in Figure 32 and Figure 34 it was required to have 3 more NEMA enclosures for the renewable energy equipment and a 60 foot pole to house the solar panel and wind turbine. All of this equipment will be discussed in the following section.

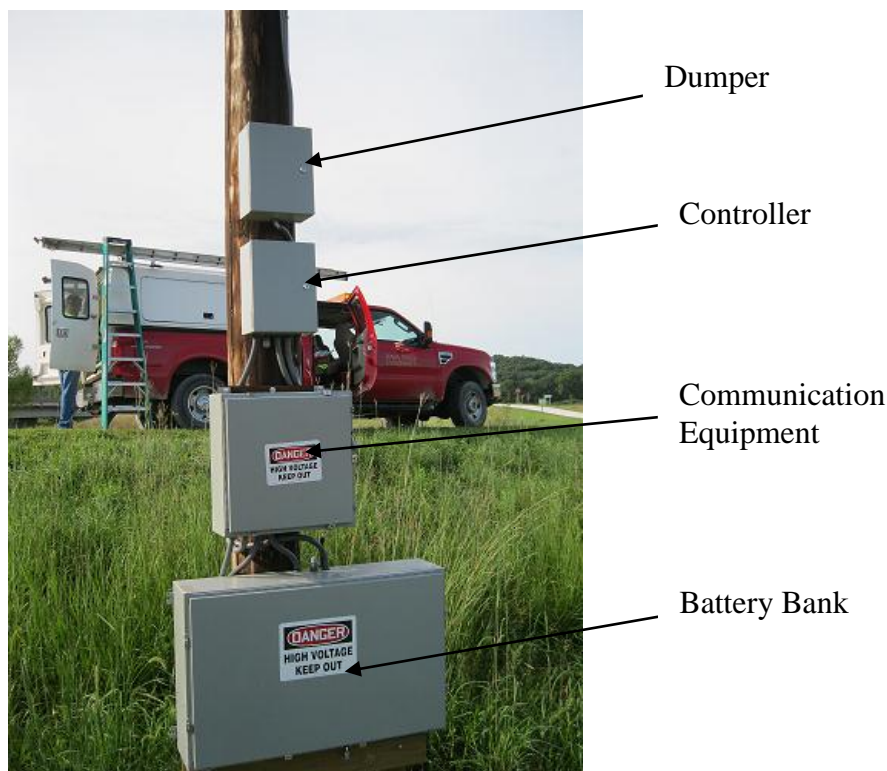

**Figure 32: Hogback Enclosure Set Up**



**Figure 33: Hogback Flame Detector**

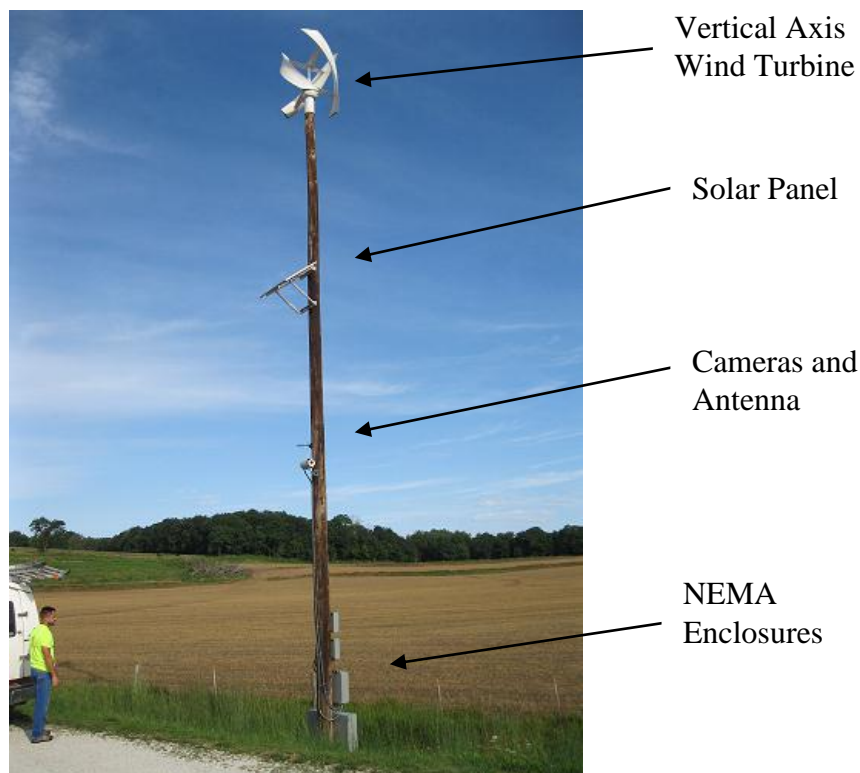

**Figure 34: Original Hogback Pole**

### 8.3.2.1 Alternative Energy System

Prior to this work the BEC had little experience with renewable energy power systems and

therefore felt it was necessary to seek the assistance of professionals in the alternate energy sector that could direct us toward an appropriately designed system. An exhaustive search for a company that could assist the project team with sizing and installation of the alternative energy system and have competitive prices was completed by the BEC. A company out of Montgomery, Illinois by the name of Sullivan Energy Group, LLC that was a provider of Urban Green alternative energy equipment proved to be the best fit for what was needed with this project. Iowa State University and Sullivan Energy Group, LLC worked together for multiple months on choosing the correct components to an alternative energy system that would efficiently and effectively power the security system for the project.

Since the rating of a solar panel or wind generator are only for ideal conditions it was important to size all of the equipment for average conditions with a certain safety factor added in case of an extended downtime in potential solar power or wind power. Looking at historical numbers from Madison County it was decided to select a 600 watt wind generator and a 150 watt solar panel with the use of a battery bank that could store reserve power for up to 3 days without stoppage of the security system.

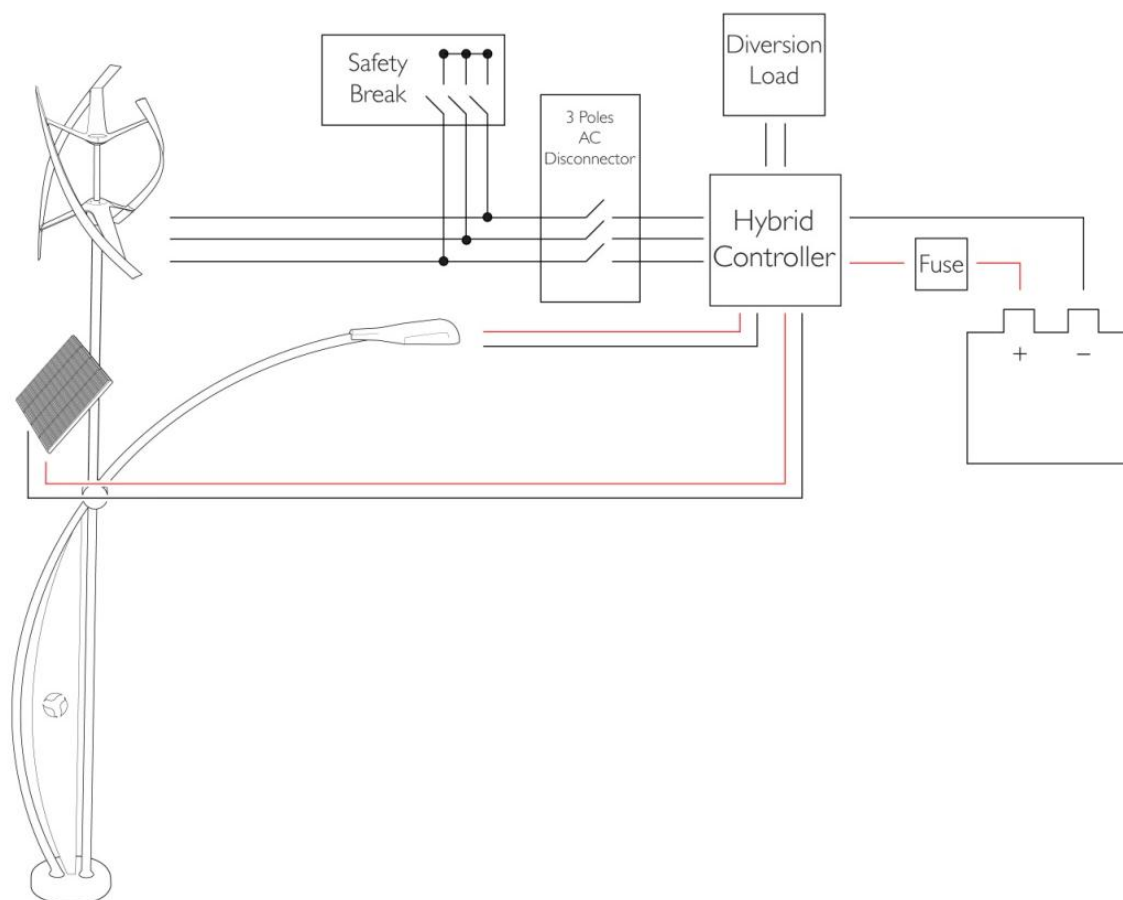

**Figure 35: Wiring Diagram for an Off-Grid System with Solar and Wind Power**

#### 8.3.2.1.1 Wind Turbine

Instead of using a horizontal axis wind turbine which is the more common type of wind generator, especially in larger applications, it was decided to use a vertical axis wind turbine that could utilize less wind speed for more power. There is also a lesser chance that the vertical axis wind turbine will be damaged by sudden wind gusts when compared with its horizontal axis counterpart, which is ideal for the applications in Madison County. Another difference between this system and others of similar size is that a proprietary pole was not used but instead a common telephone pole that was 60 feet tall was used. Most manufacturers will only warrantee their equipment if it is placed on the pole that they also manufacturer but there are manufacturers that will allow their systems to be placed on a

professionally installed telephone pole. Significant savings can be seen by not having to purchase a proprietary pole for a wind turbine or solar panel.

Figure 36 shows the construction of the wind turbine within a laboratory setting for testing of power output at different wind speeds. For a frame of reference the BEC employee in the yellow shirt in Figure 36 is approximately 6 feet tall. The BEC had the unique privilege of having ties with the Aerospace Engineering Department's Wind Tunnels at ISU so laboratory testing was practical in this situation. The testing proved inconsequential since the wind turbine could not fit within the actual wind tunnel and had to be placed in the exhaust section that could only produce wind speeds of roughly 19 miles per hour. Even with the approximate 19 mph winds coming from the wind tunnel we were unsuccessful in getting the wind turbine to 'cut in', or begin spinning from a stop, by itself. If the wind turbine was just lightly nudged with a finger however, the turbine would begin to spin and continue to spin with the wind tunnel on. It is believed that the air flow coming from the wind tunnel exhaust is not an adequate representation of the wind flow in an exterior setting. Figure 37 shows the complete assembly of the wind turbine in the laboratory setting.





**Figure 36: Assembly of 600 watt VAWT**



**Figure 37: Full Assembly of 600 watt VAWT**

### 8.3.2.1.2 Solar Panel



Source: <http://windenergy7.com/forums/viewtopic.php?p=255>

**Figure 38: Promotional Picture of Solar Panel with Mounts**

### 8.3.2.1.3 Battery Pack

The battery used for the battery bank is the SRM-4D from Interstate Batteries shown in Figure 39. Since these types of batteries were only 12 volt we had to have four batteries in the configuration of two sets of batteries in series and then the two pairs connected in parallel in order to get a 24 volt battery bank. Each individual battery had an estimated 225 amp-hours and in the configuration of the battery bank there was a total of 450 amp hours. Using only 50% of the amp hours available and with a total load of roughly 7 amp hours the battery

bank could provide power to the security system for up to 32 hours without charge from the wind and solar and with the security system running at 100% usage.



Source: <http://www.interstatebatteries.com/>

**Figure 39: SRM-4D Battery Used for Battery Bank**

#### 8.3.2.1.4 Controller

The controller used for this project was a UGE off-grid controller designed specifically for the 600 VAWT. The function of the controller is to take the variable 3-phase AC output from the permanent magnet generator and convert it to a stable 24 volt DC output to charge a battery bank. The controller also manages the turbine so that it performs safely and optimally. Figure 82 and Figure 83 show the specifications and drawings for the off-grid controller used in more detail.



Source: UGE 600W Off-Grid Controller Owner's Manual

**Figure 40: Controller for Alternative Energy System**

#### 8.3.2.1.5 Diversion Load

The diversion load is designed specifically to work with the controller for this particular set up. If there is too much charge coming from the wind and solar units at any given time the excess power goes to the diversion load which dissipates the power through the form of heat. This piece of equipment is essential in order to not over charge the system and potentially destroy the controller or batteries.



Source: UGE 600W Off-Grid Controller Owner's Manual

**Figure 41: Controller Diversion Load**

#### 8.3.2.1.6 Inverter

The inverter used for this renewable energy system was the Samplex America 300 watt, 24 volt DC-AC pure sine wave. As mentioned earlier in this report, it is essential that a pure sine wave inverter is used to have an adequate power supply. The efficiency of the inverter was 89% therefore there was an 11% loss between DC to AC which was calculated for in the sizing stages so that the loss did not affect the security system. Figure 84 shows the complete specification sheet for the inverter used as well as the specifications for the 12 volt version.



Source: [http://samlexsolar.com/customer\\_support/pdf/Specs/SA-150-112\\_124\\_Samlex\\_Specifications.pdf](http://samlexsolar.com/customer_support/pdf/Specs/SA-150-112_124_Samlex_Specifications.pdf)

**Figure 42: Samlex 24 VDC - 110 VAC Inverter**

### 8.3.2.2 Problems with Renewable Energy System

After installation of the renewable energy there were multiple problems with the power output of the system. It was found that the system could not support the monitoring system that had been installed for more than four to five days. It was decided to slowly start expanding upon the renewable energy system while trying to decrease the power demand from the monitoring system by turning off certain pieces of equipment during the different times of the day. The first change to the system was the addition of (2) 230 watt Conergy solar panels as well as a Morningstar controller that was used solely for these two solar panels. The specifications for these pieces of equipment can be seen in Figure 85 and Figure 86. Figure 43 shows the modified renewable energy system with the added solar panels. It can be seen from this photo that the extra solar panels are relatively large when compared to the original solar panel but have been successful thus far.



**Figure 43: Modified Renewable Energy System**

Currently this increase in the solar power output is keeping the monitoring system powered at all times without problem. If this system ends up not being sufficient in the future the battery bank will be doubled so that the system will have reserve power of roughly four to five days when fully charged. If both of these additions to the renewable energy system prove to be inefficient then the BEC will work directly with the manufacturer of the renewable energy system to find a solution that is both economical and permanent. Further reducing the power requirements of the monitoring system in the future is also an ongoing option that is being looked into.

### *8.3.3 Holliwell*

The first bridge to be worked on was the Holliwell Bridge located between Winterset and St. Charles. It can be seen Figure 44 that the pole was placed on top of a significant hill with heavy weeds between the bridge and the pole. An above head power line can be seen in

Figure 44 and Figure 45 which was the power source for the surveillance system. A pole that was roughly 100 yards away had power already established and it was decided that using above head power lines would be easier and more efficient than trenching between the two poles.

As mentioned earlier, the heights of the NEMA enclosures varies between the different bridges and our initial thinking was to put the boxes high enough that they would be difficult for any vandals to tamper with but still accessible with a ladder. After installing the box at the Hogback Bridge approximately 20ft above ground it was clear that this was not safe situation for anyone doing maintenance on the system, and it was mostly likely not necessary if the boxes were appropriately labeled and securely locked.

Figure 46 shows one of the optimum positions for the flame detectors to be placed within the bridge. By side mounting the detectors there was minimum interference with structural members and the best line of site was utilized. Most of the mounting positions at other bridges were somewhere between the side of the bride and the middle of the opening as with the Cutler-Donahoe and Imes Bridges. As mentioned in the Cutler-Donahoe section of this report earlier, it is essential that the aesthetics of the bridge site and the functionality of the equipment are balanced.





**Figure 44: Hollivell Pole from Bridge**



**Figure 45: Hollivell Pole**



**Figure 46: Holliwell Flame Detector**

#### 8.3.4 *Imes*

The Imes Bridge used an existing pole that was moved roughly 20 feet from its original position. The NEMA enclosure was placed at chest height which proved to be the most efficient height for protection while still allowing access into the enclosure with ease. Figure 48 shows the flame detector placement which closely resembles the Cutler-Donahoe set up in the middle of the bridge opening. There was existing power for street lamps roughly 50 feet away that was hand trenched to the pole.



**Figure 47: Imes Pole from Bridge**



**Figure 48: Imes Flame Detector**

### *8.3.5 Roseman*

The Roseman Bridge was one of the easier bridge set-ups because there was an existing pole

in an optimum position that already had power ran to it from a previous project. This allowed for minimum disturbance with the aesthetic value of the bridge site since very little had to be changed in order to install the security system. Figure 51 shows the positioning of the flame detector which is halfway between the middle of the opening and the side of the bridge. Because of the architecture of the bridge this proved to be the optimum position for the flame detectors with direct line of site to the middle of the bridge.



**Figure 49: Roseman Pole from Bridge**



**Figure 50: Roseman Pole**



**Figure 51: Roseman Flame Detector**

## 8.4 Testing

In field testing was performed at all five bridge sites to ensure that all equipment was operating properly. This entailed a pan that was 1 foot in diameter being placed on a cart so the fire could be easily moved along the length of the bridge with the fire consisting of charcoal with lighter fluid to start it and make it larger when necessary. It should be noted that safety is the most important part of any in field testing that includes an open flame. Buckets of water and fire extinguishers should be close at hand as seen in both Figure 52 and Figure 53. It is also essential to inform all local authorities such as police and fire departments that open flame tests will be conducted to ensure any alarms or notifications from passer byers can be ignored during a certain time frame.

The test started in the middle of the bridge span directly between the two flame detectors on either end. For some of the detectors to be set off the fire had to be pushed roughly 10 feet towards the end of the bridge due to direct line of site limitations to the center of the bridge. There was problems with 4 of the flame detectors and were returned to the manufacturer but they were promptly replaced and in functional order. These problems could have been due to wiring problems inside of the NEME enclosure because of poor wire schematics. It is essential to fully label and follow all wiring diagrams to ensure the safety of all equipment being used with the monitoring system.



**Figure 52: Required Material for Flame Test**



**Figure 53: Flame Test Being Conducted**

The flame detectors were able to visually show that an alarm had been set off through the use of LED lights that could be seen through the wire mesh in the wooden boxes. Figure 54 shows a flame detector that is not set off and in working order. It visually shows that it is monitoring the bridge by blinking the LED lights every 15 seconds. Figure 55 shows a flame detector that was triggered during the fire testing. The red LED lights are constantly on and

stay on until the system is reset via either internet connection or by simply cycling the power off and on.



**Figure 54: Flame Detector Prior to Alarm**



**Figure 55: Flame Detector after Alarm Set Off**

After the flame detectors were found to be in working order the same fire was started at the opening of the bridge on the side facing the IR and optical camera. Only the IR camera has the capability of setting off an alarm if a fire is present and there is no visual display to show



if it is working properly as with the flame detectors. In order to complete this test an internet connection or direct local connection was required to monitor the operation of the IR cameras. Once the IR camera would capture a temperature that exceeded the threshold temperature preset through the software an email would be sent out and the optical camera would capture a certain length of recorded video. This recorded video is essential in case something else reaches the threshold temperature such as a lawn mower engine or light reflecting off a surrounding surface. This proved to be a small problem for the Iowa State research team with lawn mowers going through the bridge site area and light reflecting perfectly off the river below the bridge at a certain time of day. Both of these issues caused false alarms for the IR camera.

## CHAPTER 9 CASE STUDIES

An expansive search was conducted by the Iowa State University to find different projects throughout the United States that included adding monitoring devices and different security equipment on covered bridge sites. There were very few covered bridges that were installing any monitoring devices and a couple that were adding other security systems such as lighting or fences. The majority of security installations dealt with structural strengthening and renovations to the bridges such as applying fire resistant materials to the bridges. These types of projects were not included in to the case studies since they did not add any sort of monitoring system on to the bridges.

## 9.1 Union County Covered Bridges

### **Bridge Names:**

Bigelow Bridge  
Pottersburg Bridge  
Culberson Bridge

### **Bridge Owner:**

Union County Commissioners

### **Bridge Location:**

Union County, Ohio

### **Initial Price of Security System:**

\$215,619.00 (for all three bridges)



Source: <http://www.redbubble.com/people/monnier>

**Figure 56: Bigelow Covered Bridge**

### **Bridge History:**

There have been arson and vandalism problems with these bridges in Union County, Ohio but nothing major to this point. There have been fire problems from people starting camp fires on the river banks under the bridges but nothing that appeared to be intentionally set.

### **Security System Overview:**

The security systems on these bridges utilize a linear heat detection cable that is located along the edges of the truss space as well as one cable down the center of the ceiling space. A Fenwall system with a Honeywell remote dialer was used for the linear heat detection system. There are also two cables running the width of the bridge above the abutment areas of each bridge (Cable placement shown in above image). Once the detection cable is set off by a certain temperature there is an alarm sent to the fire department as well as an audible and visual alarm that is set off once the detection cable reaches a certain temperature. All four bridges were also equipped with Tokistar LED lights that had to be modified for the vibration from traffic on the bridges located under the roof under hang to aesthetically wash down the walls of each bridge. The LED lighting is used to make the structures more visual to reduce the chances of someone damaging the bridge during nighttime.

## 9.2 Knecht's Covered Bridge

**Bridge Name:**

Knecht's Covered Bridge

**Bridge Owner:**

Bucks County, Pennsylvania

**Bridge Location:**

Springtown, Pennsylvania

**Initial Price of Security System:**

\$35,000.00

**Source of Funding:**

Privately funded

**Year Installed:**

2011

**Bridge History:**

Bucks County has lost three covered bridges since 1985 due to arson and almost lost another one when Knecht's Covered Bridge was set on fire twice over a three year span with the last attack in 2007. Hay bales were placed on the bridge with a trail of accelerant and lit by a match. Fortunately for Bucks County the hay was damp so it smoldered instead of becoming set ablaze.

**Security System Overview:**

The security system for the Knecht's Covered Bridge included an alarm system consisting of strobes and horns if any alarm was set off. These alarms were connected to a linear heat detection system that was all controlled by a control panel that was enclosed in a NEMA 4 enclosure. There is also a dry standpipe sprinkler system across the length of the bridge to protect in case of any fire reaching a certain temperature threshold to set off the system.



Source: <http://bridgehunter.com>

**Figure 57: Knecht's Covered Bridge**

### 9.3 Pomeroy-Academia Covered Bridge

**Bridge Name:**

Pomeroy Academia Covered Bridge

**Bridge Owner:**

Juanita County Historical Society

**Bridge Location:**

Port Royal, Pennsylvania

**Initial Price of Security System:**

\$16,600.00



Source: <http://handwovenlife.blogspot.com>

**Figure 58: Pomeroy-Academia Covered Bridge**

**Bridge History:**

It is unknown exactly when the Academia Covered Bridge was originally built but this bridge was destroyed by ice floating down the river in 1901 and promptly replaced with a new bridge that still stands today. In 1962 the Pomeroy Academia Covered Bridge was scheduled to be completely destroyed and replaced with a new concrete bridge to span the river. The Juanita County Historical Society took prompt action and acquired the bridge and allowed it to stand.

In June of 2009, weeks after \$1.4 million was put into restoration of the bridge, there was an arson attempt at the Pomeroy Academia Covered Bridge by suspected locals. The individuals lit articles of clothing on fire and damaged some of the bridge deck. A few days later the same individuals, as thought by the local police, returned to extensively spray paint graffiti throughout the bridge.

**Security System Overview:**

An 8 camera security system was placed throughout the bridge site as well as within the bridge itself for a total of \$14,000 and all the graffiti was removed and a coating of fire retardant was applied to the burned area for a total of \$2,600.

## 9.4 Cedar Covered Bridge

### **Bridge Name:**

Cedar Bridge

### **Bridge Owner:**

Madison County, Iowa

### **Bridge Location:**

Madison County, Iowa

### **Source of Funding**

Federal



Source: Remote Monitoring of Covered Bridges

**Figure 59: Camera System Used on Cedar Covered Bridge**

### **Bridge History:**

The Cedar Bridge was a major bridge in the 1992 book The Bridges of Madison County that was Oprah's "book of the year" in 1993. In 2002 the Cedar Bridge was completely destroyed by arson and was unable to be saved. The town decided to rebuild the bridge with the same construction methods and materials as the original bridge and it was completed in 2004.

### **Security System Overview:**

An extensive security system was installed on the Cedar Bridge with a grant from the Federal Government. This integrated system included an infrared camera, fiber optic sensors, and two flame detectors at either end of the bridge.

### **Security System Technical Data:**

#### **Major Equipment**

1-FLIR model A-20 M

2-Fire Sentry Corporation SS4-A UV/IR Electro-Optical Digital Fire Detectors were used with the specification of the detection of a 1 square foot fire at 15 feet within 5 seconds.

12-Fiber Bragg Grating fiber optic sensors were used

1-Micron Optics SI-425 Interrogator

### **Additional Information:**

A detailed report for this project can be found by the report titles "Remote Monitoring of Historic Covered Bridges" by Iowa State University in November of 2006.

## 9.5 Illinois Covered Bridges

### **Bridge Name:**

Red Covered Bridge  
Thompson Mill Covered Bridge

### **Bridge Owner:**

Illinois Department of Transportation

### **Bridge Location:**

Bureau County (Red Covered Bridge)  
Shelby County (Thompson Mill Covered Bridge)  
Source: <http://bureaucountybridges.us>



**Figure 60: Red Covered Bridge**

### **Initial Price of Security System:**

\$74,450.00 (Red Covered Bridge)  
\$71,090.92 (Thompson Mill Covered Bridge)

### **Year Installed:**

2005 (Both Bridges)

### **Bridge History:**

Before the improved security systems were installed on this bridge there were some basic light fixtures located in the interior and openings of the bridges. These basic fixtures included three wall mounted luminaires located inside of the bridges and one pole mounted luminaire on the North approach. These light fixtures will remain on the bridge and can be seen on the attached plan sheet.

### **Security System Overview:**

There were two light fixtures installed on the bridge during the security system improvement. These light fixtures will be controlled by photocells which will act as sensors so they will turn on whenever the light levels fall below a certain threshold that the design sets. There is a single architectural floodlight on the South approach so that both of the approaches are lit. There is also a triple architectural floodlight that is directed at the existing parking lot which is to remain after the renovation. After the renovation to the lighting system the interior of the bridge, both approaches, and the parking lot will be completely lit during all hours of the day.

Along with the increased lighting there will also be five cameras placed throughout the bridge site. There will be a camera in the entrance on both the North and South side of bridge facing towards the center so the entire interior of the bridge is under surveillance. There is also a camera on the ends of both the North and South approaches facing towards the entrances of the bridge. A camera will also be mounted with the triple architectural floodlight facing towards the mechanical building.



## **APPENDIX A CREATIVE COMPONENT: INSTALLATION OF SECURITY SYSTEM IN MADISON COUNTY**

This research project involved the creation of a manual intended to assist covered bridge owners in their decisions regarding security and monitoring systems for covered bridges. This manual alone did not satisfy the Graduate College's thesis requirements for a creative component. It was decided that the intense involvement required in both Ames, Iowa and Madison County, Iowa during the installation of the monitoring systems satisfied these requirements. This section of the thesis is intended to fulfill the creative component requirement by fully outlining the process of installing the monitoring system in Madison County, Iowa.

### **A.1 Pole Site Selection**

The first major undertaking by the design team was to choose the location of the poles at each of the five bridge locations. This proved to be a major undertaking since permission by a Winterset city board was required before any installation of said poles was allowed. In order to expedite the process the design team chose multiple locations that would meet the requirements of maximum distance from the bridge as well as line of site to the bridge. After discussing with the IT professional, who designed the monitoring system, the design team had general ideas of the limitations of the cameras that were being used for the system.

The first site visit to the bridge sites by the design team was with both the optical camera and the infrared camera. Both sides of the bridge were fully surveyed to see which location of the pole would provide the best line of site to both sides of the bridge with as much of the inside of the bridge as possible while still staying within a range of 50-150 feet. Multiple locations were selected at each bridge site and photographs were taken with both cameras at all possible locations to be analyzed later by the design team at BEC.

Once back in Ames, Iowa the design team chose two different possible pole locations at each bridge site and prepared a presentation for the Winterset city board that had to approve of the said locations. AutoCAD drawings were created with all possible pole locations indicated as

well as all pictures taken by the optical camera for the city board to review. Fortunately for the design team all of the best pole locations were approved by the city board.

## **A.2 NEMA Enclosure Selection**

As mentioned later on in this thesis is it essential that a proper enclosure is selected. After an investigation of what type of enclosure would prove to be the best with consideration of functionality as well as economy it was decided to use a NEMA enclosure purchased from the website Automation Direct. After looking at all levels of NEMA ratings it was decided that a NEMA 4 enclosure would be secure enough for the locations they would be installed in while still being affordable for the project budget.

NEMA 4 enclosures are constructed for either indoor or outdoor use to provide a degree of protection against incidental contact with the enclosed equipment; to provide a degree of protection against falling dirt, rain, sleet, snow, windblown dust, splashing water, and hose-directed water; and will be undamaged by the external formation of ice on the enclosure. This met all the criteria by the design team due to the environment at the bridge sites. This specific type of enclosure allowed the use of a padlock or other locking device chosen by the customer and was also an attractive option for the design team so any individual could access the enclosure as long as he or she possessed the key to the lock.

The sizing of the NEMA enclosure included an AutoCAD schematic that included all pieces of equipment required to be within the enclosure. It can be seen in Figure 61 that a 24" x 24" enclosure would be oversized sized so a 24" x 20" enclosure was finally decided upon. Figure 62 shows that it was fortunate that a smaller enclosure was not selected since it was a tight fit after all equipment and wiring was installed. The addition of an IP switch came later on in the project to allow the design team to remotely turn equipment on and off and can be seen as the black box in front of the PC computer. This only added to the congestion in the box but was still able to fit with careful planning by the design team.

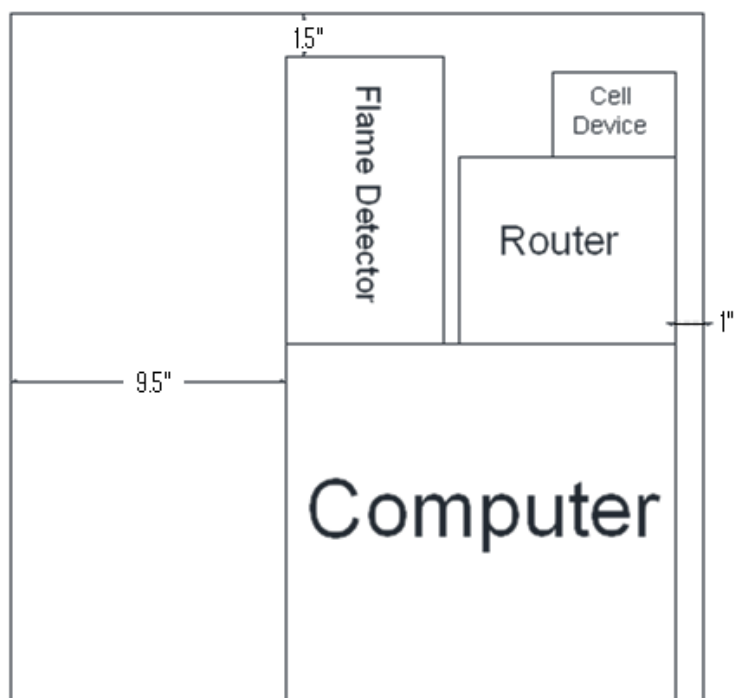

**Figure 61: Schematic of NEMA 24''x 24'' enclosure**

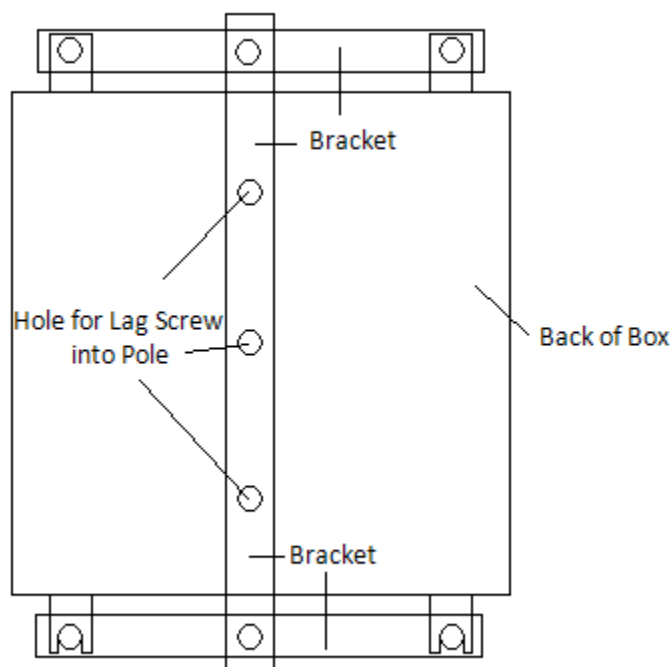

**Figure 62: Inside of Typical NEMA Enclosure**

As seen in Figure 62 there were major modifications to the box that were required. These modifications included four holes in the bottom of the enclosure to allow the city power, flame detector wire, IR camera power, and antenna/optical camera wire to enter. At the first bridge to have the enclosure installed, Holliwell, it was necessary to drill these holes after the enclosure had already been secured to the pole. This proved to be a very difficult task since the enclosure was placed roughly 15 feet off the ground. The other four enclosures had these holes drilled at the Iowa State structural laboratory for ease of construction.

As discussed in the previous paragraph, the Holliwell enclosure was placed roughly 15 feet off the ground. This proved to be very inconvenient and dangerous for the design team when installing or servicing the equipment later on in the project. The next two enclosures at Cutler-Donahoe and Roseman were set at roughly 8 feet off the ground and this also proved to be an unnecessary inconvenience so the last two enclosures at Imes and Hogback were set near chest level so a ladder was not required when installing or servicing the equipment at a later date.

Since the NEMA 4 enclosures purchased were meant to be installed on a flat surface it was required to create a bracket system that would allow it to be mounted on a roughly one foot diameter telephone pole that was used at all bridge locations. The design team decided on using metal brackets that were 3/8" thick and 2" wide. This size of metal proved able to easily support the box without extraneous swaying or movement. In Figure 63 the general layout of the brackets can be seen. The bracket running down the middle of the box used (4) 3.5" lag screws to secure the box to the pole. Eye hole bolts were used on the four corners to fasten the bracket system to the box. The first three enclosures used airplane wires between the two eye hole bolts on the top and eye hole bolts on the bottom to go around the pole and give the enclosure more stability. This was not done on the final two enclosures because it did not appear to give much added strength.



**Figure 63: NEMA Enclosure Brackets for Pole Mount**

### A.3 Install Flame Detectors

The flame detectors were installed within the covered bridges and all necessary wire ran between the pole and detectors before the installation of the cameras. The installation of the flame detectors were a much more time consuming job when compared to the cameras since all wire had to be ran through the bridge structure and then underground between the pole and bridge.

The county engineer for Madison County, Todd Hagan, chose a trenching company to do all of the trenching between the bridge and the pole. For four of the bridge sites a simple open trench was acceptable due to the terrain between the two ends but at the Cutler-Donahoe bridge site a newly paved trail through the city park proved to be a hassle. It was decided that the only option for running the wire between the pole and the bridge was to have a directional bore come to the site and assist in running the wire beneath the pavement.

Unfortunately due to miscommunication the directional bore had to come to the Cutler-Donahoe bridge site twice. The city ran their power underneath the paved trail before communicating with the design team so they could also run their flame detector wire in the same directional bore. The directional bore proved to be a much less time consuming activity and less destructive to the bridge site when compared to open trenching but since time and site disturbance wasn't an issue on the other four bridge sites the financial difference between the two methods proved to be too great.

Once the wire was ran to the end of the bridge approach it was necessary to navigate the wire through the actual bridge structure to the points where the flame detectors would roughly go. It was essential that all of the wire be placed as to be as unseen as possible while still providing it with protection from insects, animals, and trespassers. The ability for the design team to easily move the wire through the bridge structures differed from bridge to bridge. Some of the bridges allowed for the wire to be placed underneath the bridge structure while others required the wire to be placed towards the top structural members.

After all wire was run to the bridge site and through the structure it was decided where each flame detector would be placed. The ideal location for the flame detectors would give them the ability to see just past the center of the bridge span with as little interference along the way with structural members. This proved to more of a problem than originally anticipated since all five bridges were significantly different in the way that they were constructed and provided the design team with multiple mounting situations as well as structural members to interfere with line of a sight to the center of the bridge span.

All five bridges did provide the design team with at least one location on each end of the span to mount the camera while still allowing the detectors to view the center of the bridge span within reason and no more than 25% - 50% of the view interfered with through structural members. Through testing, which is discussed in full detail later on this section as well as the testing section within the manual portion of this thesis, it was proven that the

detectors were placed in locations that could view the center of the bridge span within five to ten feet.



**Figure 64: Flame Detectors with and without Wood Coverings**

Since the flame detectors were white and very exposed when installed towards the top portion of the bridge locations the design team decided to cover the detectors with a wooden box, as done in a similar project involving flame detectors in 2005, and paint the cover of the flame detector black to camouflage the detector within the wooden box. The wooden box

was constructed to give off the impression of a bird house while still blending in with the surrounding structural members as best as possible. The difference between using a covering and not using a covering can be seen in Figure 64.

#### **A.4 Install Cameras and Antennas**

Once all of the flame detectors were installed the design team fully installed all of the cameras and antennas. The entire design team had to be present as well as some additional helpers during this installation process. Installation of both cameras and an antenna at each bridge site took two full days since a lift was required that became difficult to navigate around the monitoring system's poles. The use of generator power was required at three of the bridge sites since the renewable energy system, discussed in the next section, was not functional during this period of time and two other bridges did not have power brought to the pole due to three to four weeks of substantial downpour before the day of installation.

In order to expedite the installation at the bridge site while the lift was still being rented it was decided to do as much of the work in the Iowa State structural laboratory as possible. This included running all necessary wires through the flexible conduit that was to be run between the cameras and the NEMA enclosure as well as placing the IR camera into its enclosure and making sure all camera and antenna components were as weather proof as possible before being sent to the field for installation. Once all of the equipment required for installation was as prepared as possible it was sent to the field along with the rented lift.





**Figure 65: Complete Pole after Installation**

Installation included having two design members in the lift to position and install all of the cameras, one member in the NEMA enclosure to cut all flexible conduit to the correct size and make all necessary connections to the equipment inside of the NEMA enclosure, and an IT professional to access the cameras remotely or locally in order to correctly position both cameras and antennas in the best possible location. In order to expedite the process there was one other member that was on the ground in order to assist the members in the lift as well as the member working in the NEMA enclosure. The most difficult part of installation was

positioning the lift in the correct spot to get the best possible angle for installation. Since most of the poles were in hard to reach areas it was a very time consuming part of installation. A typical pole can be seen in Figure 65 with both cameras and the antenna located towards the top of the pole and the NEMA enclosure towards the bottom of the pole.

## **A.5 Renewable Energy System**

The Hogback Bridge site was in an isolated area that would require a substantial amount of money in order to get city power to the pole location. The design team made the decision to use a standalone renewable energy system to power the monitoring system at Hogback. Since no one on the design team had designed or installed such a sizeable renewable energy system it was decided to employ an outside company to help design the system for the monitoring system that would be powered.

### *A.5.1 Renewable Energy System Manufacturer Decided Upon*

After giving consideration to multiple companies it was decided that Sullivan Energy Group out of Montgomery, Illinois would be the best fit for our project. Sullivan Energy Group decided that a 600 watt vertical axis wind turbine with the addition of a 150 watt solar panels would suffice for the amount of power input that would be needed for the monitoring system. The battery bank was sized by DEKA battery given our requirements of a four to five day battery bank with the draw that we would be putting on the system. DEKA stated that we would need roughly 450 amp-hours for the monitoring system we were powering. This should have provided us with roughly 3-4 days of reserve power.

### *A.5.2 Installation of Renewable Energy System*

Much like the installation of the cameras and antennas, multiple people were required to install the renewable energy system at Hogback. A 60 foot lift was required as well since the vertical axis wind turbine was installed on a 60 foot telephone pole. The pole was set next to the roadway which was roughly 10-15 feet up from the bottom of the pole so the 60 foot lift was more than adequate. The installation team included two design team members in the lift,

one member in the NEMA enclosures to make all necessary connections, and one member to be on the ground to assist all personnel in either the lift or in the enclosures. All major installation was able to be completed within one day with just minor adjustments required later on. Figure 66 shows the completed installation of the original renewable energy system.

To ensure that the team knew how to install the turbine and the solar pane the entire system was built in the Iowa State structural laboratory to ensure that all pieces were shipped and that the installation would go as smoothly as possible. The wind turbine and solar panel were then partially disassembled so that they could easily be lifted and maneuvered in the field. Unfortunately an incorrect size of wiring was put through the flexible conduit in the structural laboratory and had to be pulled out in the field with a bigger gauge of wire pulled through.

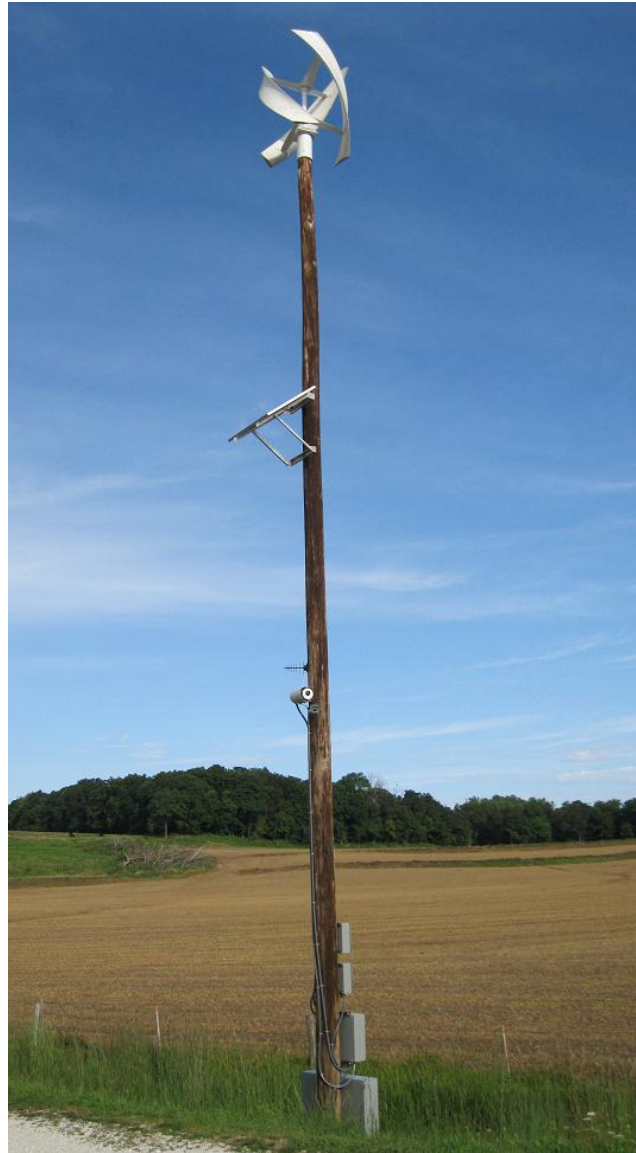

**Figure 66: Hogback Renewable Energy System**

### *A.5.3 Troubleshooting of Renewable Energy*

After the renewable energy system was completely installed the system would only support the monitoring system for a few days before there was not enough reserve power and the system would shut down. It was decided to recalculate some numbers in order to see if the system was under designed and would have to be increased in order to support the monitoring system. Unfortunately Sullivan Energy Group did not respond to multiple emails or assist in this reevaluation so all calculations had to be done by the design team.

The actual calculations completed by the design team were significantly more involved than the following but were truncated to only the final calculations. All of the following calculations show the numbers for the final renewable energy system that was placed at Hogback. Most of the efficiencies for the system are educated, conservative estimates by the design team unless otherwise stated that it was found through any other means.

#### A.5.3.1 Draw Calculations

The design team measured the input required for the monitoring system in the Iowa State structural laboratory. The highest measurement was 1 amp at 120 VAC. The battery bank that would be supplying the monitoring system consists of four 12 volt batteries connected in series and parallel to create a battery bank consisting of 24 VDC with the amp-hours of two batteries. Converting the amperage from AC to DC required the following calculation:

$$(120 \text{ VAC})(1 \text{ amp}) = (24 \text{ VDC})(\# \text{ amps})$$

$$\# \text{ amps} = 5 \text{ amps DC}$$

The manual for the inverter selected for this project stated it had an efficiency of 90%. This further increased the necessary amperage.

$$\frac{5 \text{ amps}}{0.9} = 5.5555 \text{ amps} \quad (5.56 \text{ amps})$$

The design team decided that one way to minimize the draw from the power system was to have it run for 5 minutes and then have it partially shut off for 15 minutes. It was assumed that partially shutting off the system reduced the draw by 75%.

5 min on: 5.56 amps

15 min partially off:  $(0.25)(5.56 \text{ amps}) = 1.39 \text{ amps}$

$(0.25)(5.56 \text{ amps}) + (0.75)(1.39 \text{ amps}) = 2.43 \text{ amps}$

After figuring out the adjusted draw of the system it was required to convert the units into total watt-hours required to run the system every 24 hours.

$(24 \text{ VDC})(2.43 \text{ amps}) = 58.32 \text{ Watts}$

$(58.32 \text{ Watts})(24 \text{ hours}) = 1,400 \text{ Watt-hours}$

#### A.5.3.2 Solar Calculations

In order to have a conservative estimate on how much power the renewable energy system would be generating it was decided to ignore the effects of the wind turbine since the power it created could vary greatly throughout different times of the year. The first calculation considered how much solar power would have to be generated to power the monitoring system assuming 75% of the maximum output for 5 hours a day.

$$P_{\text{Solar}} = \frac{1,400 \text{ Watt-hours}}{0.75} = 1,867 \text{ Watt-hours}$$

$$P_{\text{Solar}} = \frac{1,867 \text{ Watt-hours}}{5 \text{ hours}} = 374 \text{ Watts}$$

$$P_{\text{Solar}} \geq 374 \text{ Watts}$$

#### A.5.3.3 Battery Bank Calculations

As mentioned earlier, the battery bank included four 12 volt batteries that had 225 amp-hours each. When connected in series and parallel it created a battery bank consisting of 24 VDC

and 450 amp-hours. A conservative assumption of 80% efficiency was selected for the battery bank.

$$P_{\text{Battery}} = (24 \text{ volt})(450 \text{ amp-hours}) = 10,800 \text{ Watt-hours}$$

$$P_{\text{Battery}} = (10,800 \text{ Watt-hours})(0.8) = 8,640 \text{ Watt-hours}$$

Unfortunately a battery cannot use 100% of its amp-hours without critical damage to the unit and making it very difficult to recharge. After researching different battery companies it was decided to not allow the battery bank to fall below 50% of its amp hours in order to extend the life of the battery bank for as long as possible.

$$P_{\text{Battery}} = (8,640 \text{ Watt-hours})(0.5) = 4,320 \text{ Watt-hours}$$

Once the total Watt-hours are determined within a safe range the length of reserve power can be calculated.

$$\frac{4,320 \text{ Watt-hours}}{\left(1,400 \frac{\text{Watt-hours}}{\text{Day}}\right)} = 3.1 \text{ Days of Reserve Power}$$

#### *A.5.4 Analyzing Options for Renewable Energy Upgrade*

After looking at the previous calculations it is obvious that something had to be upgraded or altered with the Hogback System in order for it to be able to sustain itself without constant maintenance and supervision. The obvious options for the design team were to add solar power, add batteries, or reduce draw from the monitoring system. Instead of upgrading all portions of the system at one time it was decided that a more economical decision was to upgrade portions of the system in phases to see the effectiveness of each solution.

#### A.5.4.1 Addition of Solar Panels

It was decided to first increase the power supply since the 150 solar panel that was originally included in the renewable energy system did not meet or exceed the 374 watt minimum according to the design team's calculations. There were multiple different criteria to look at when selecting a type of solar panel. The three most important criteria looked at by the design team were price, power output, and size. The average price for the solar panels that the team looked at was roughly \$2.00 to \$3.00 per watt and an average output of 12 to 14 watts per square foot of solar panel.

An important lesson learned by the design team was the size of solar panel required to charge the battery bank. The peak output for a 20 volt solar panel was over 24 volts and the team decided that this would charge the 24 volt battery bank sufficiently. Luckily the team consulted with a professional in renewable energy system design and were told that the 20 volt solar panels would not fully charge the 24 volt battery bank and the system would end up never reaching its full potential. It was found that a solar panel that is the same voltage as your battery bank is required for the battery bank to ever become full charged regardless of the peak voltage of the solar panel.

After a thorough search of different solar companies it was decided to use two 230 watt solar in the system to combine for a total of 460 watts of solar power. This amount of solar panel was significantly more than required by our initial calculations of 374 watts but due to the lower cost of the solar panels selected when compared to the entire system it was decided that the added cost was worth the extra security obtained when installing these solar panels.

#### A.5.4.2 Addition of Batteries to Battery Bank

The second option that was seriously looked at by the design team was the expansion of the battery bank. For the original renewable energy system it was not much of an option since it was thought that the energy system was never fully charging the existing battery bank. If the upgraded renewable energy system was fully charging the battery bank with four batteries but the reserve time was proving to be inadequate then the addition of more batteries was a



viable option. Any expansion of the battery bank had to come at two batteries at a time in order to maintain the 24 volt system since the system had 12 volt batteries ran in series and parallel. Every set of two batteries added to the battery bank would increase the amp-hours of the total system by roughly 250 amp hours. The increase in amp hours would increase the reserve capacity of the system by a total of one and a half days.

#### A.5.4.3 Reduction of Draw from Monitoring System

The calculations for draw are shown in the previous section as running at 25% for 15 minutes and at 100% for 5 minutes. These are conservative estimates of the actual draw from the altered system. The design team had the ability to change the time intervals that the equipment could be operational due to the IP switch that allowed four pieces of equipment to be plugged into it. The equipment that was plugged in to the IP switch was the router, IR camera, flame detector, and the computer. On all bridges the router was turned off for 1 minute during the middle of the day. It was found that the router would malfunction after some time and had to be restarted occasionally so it was decided to restart it daily in order to avoid this problem. This was the only piece of equipment that had its power cycled throughout the day on the four other bridges. The Hogback Bridge required that all equipment plugged into the IP switch be cycled in order to reduce draw.

The altered system still had the optical camera and modem operating all at times but had all other equipment running in different cycles to reduce draw. The infrared camera was set to only run from 10:00 PM until 6:00 AM every day since these times are the most likely for any problems with arson or trespassing. Also these will be the times that the optical camera will be obsolete due to improper lighting. It was decided that the flame detectors did not need to be running at all times and could be ran intermittently and still be effective. The time interval chosen was 5 minutes on and 15 minutes off. It was decided that this time interval would be effective while still significantly reducing the draw of the system. This only required the flame detector to be inoperable for 15 to 16 minutes while the system rebooted from shut down. These time intervals can be changed by the design team in the future if it is found that they are not secure enough or if it is found that the renewable energy system can

handle a larger draw than it currently supports.

#### A.5.4.3 Final Solution

Figure 67 shows the renewable energy system with the upgraded solar power. The two 230 watt solar panels are much larger than their 150 watt counterpart but have maintained the system since September 19<sup>th</sup> and kept the battery bank almost fully charged during the four weekly checks since the system has been installed. If this upgraded system proves to not work at any later date the option of upgrading the battery bank will be looked further into as well as the possibility of even further diminishing the draw of the monitoring system.



**Figure 67: Upgraded Renewable Energy System**

### **A.6 Testing of Monitoring Systems**

In-field testing was performed at all five bridge sites to ensure that all equipment was operating properly. This entailed a pan that was 1 foot in diameter being placed on a cart so the fire could be easily moved along the length of the bridge with the fire consisting of charcoal with lighter fluid to start it and make it larger when necessary. It should be noted that safety was the most important aspect while field testing with an open flame. Buckets of

water and fire extinguishers were close at hand as seen in both Figure 52 and Figure 53. All local authorities, such as police and fire departments, were informed by the design team that open flame tests were being conducted to ensure any alarms or notifications from passer byers would be ignored during the time of testing.

At each bridge the test started in the middle of the bridge span directly between the two flame detectors on either end. For some of the detectors to be set off the fire had to be pushed roughly 10 feet towards the end of the bridge due to direct line of site limitations to the center of the bridge. There were problems with 5 of the flame detectors and were returned to the manufacturer but they were promptly replaced and in functional order. These problems could have been due to wiring problems inside of the NEMA enclosure because of poor wire schematics. It is essential to fully label and follow all wiring diagrams to ensure the safety of all equipment being used with the monitoring system.



**Figure 68: Required Material for Flame Test**



**Figure 69: Flame Test Being Conducted**

The flame detectors were able to visually show that an alarm had been set off through the use of LED lights that could be seen through the wire mesh in the wooden boxes. Figure 54 shows a flame detector that is not set off and in working order. It visually shows that it is monitoring the bridge by blinking the LED lights every 15 seconds. Figure 55 shows a flame detector that was triggered during the fire testing. The red LED lights are constantly on and stay on until the system is reset via either internet connection or by simply cycling the power off and on.



**Figure 70: Flame Detector Prior to Alarm**



**Figure 71: Flame Detector after Alarm Set Off**

After the flame detectors were found to be in working order the same fire was started at the opening of the bridge on the side facing the IR and optical camera. Only the IR camera has the capability of setting off an alarm if a fire is present and there is no visual display to show if it is working properly as with the flame detectors. In order to complete this test an internet connection or direct local connection was required to monitor the operation of the IR cameras. Once the IR camera would capture a temperature that exceeded the threshold temperature preset through the software an email would be sent out and the optical camera would capture a certain length of recorded video. This recorded video is essential in case something else reaches the threshold temperature such as a lawn mower engine or light reflecting off a surrounding surface. This proved to be a small problem for the Iowa State research team with lawn mowers going through the bridge site area and light reflecting perfectly off the river below the bridge at a certain time of day. Both of these issues caused false alarms for the IR camera.

## APPENDIX B DECISION MAKING TOOL

An electronic decision making tool that has been created by Iowa State University will be available to covered bridge owners along with this manual. This will lessen the amount of work required by the bridge owners since they will not have to navigate flow charts and spreadsheets. The digital decision making tool asks the owner multiple questions including funding available, surrounding bridge environment, and past problems with arson or vandalism. These questions will direct the owners in a certain direction for emphasizing deter, deny, detect, and defend depending on the way that they answer the prompt questions. The problem runs mostly with if statements within Excel and also uses Visual Basic for some functions.

The user interface for the decision making tool is shown in Figure 72. The only input required from the covered bridge owner is what is written in red. Each red box has a drop down menu with a preselected number of options or allows the user to input a number. Once a bridge owner has selected an appropriate option for all categories within the user interface page multiple calculations will take place as shown in Figure 73. Based upon these calculations the equipment options are ranked by an Importance Factor within the Recommendations page as shown in Figure 74. All options are color coded by deter, deny, detect, and defend with a note stating that a bridge owner should ensure that all areas of bridge security are properly covered in order to have an efficient system.

The calculations are based on certain weights and criteria that can be easily manipulated if something must be changed. The following is a brief explanation of all columns within the Required Calculations Page:

### **Price:**

This column takes the price of all equipment and ensures that none of the equipment will cost more than half of the price range available for the entire security system. If the piece of equipment costs less than half of the entire budget then a 1 is placed in the last column of the price category and if it costs over half then a 0 is placed in the final column. These numbers

will be discussed later in the Summed description.

**Fencing:**

If the question “Ability to Use Fencing at Bridge Site” is answered yes then a 1 is placed in the column for all fencing options. If the answer is no then a 0 is placed in the column for all fencing options. All other equipment has a 1 in this column.

**Electric:**

If the question “Ability to Use Electrical Components” is answered with yes then a 1 is placed in the column for all equipment that requires electricity. If the answer is no then a 0 is placed in the column for all equipment that requires electricity. All other equipment that does not require electricity has a 1 in this column.

**Water:**

If the question “Ability to Use Water Hook-up” is answered with yes then a 1 is placed in the column for all equipment that requires a water hook-up. If the answer is no then a 0 is placed in the column for all equipment that requires a water hook-up. All other equipment that does not require a water hook-up has a 1 in this column.

**Exist:**

If any equipment answers the “Current Equipment on Site” question with yes then a 0 will be placed within this column for that piece of equipment. If no is answered then a 1 will be placed within this column.



**Traffic:**

If the question “Vehicles Allowed on Bridge” is answered with no then a 1 is placed in the column for bollards and decorative planters. If the answer is yes then a 0 is placed in the column. A 1 is placed in the column for all other equipment.

**Summed:**

The Summed Column multiplies all of the previous columns together that either have a 1 or a 0 in them to an answer of either 1 or 0. If any column has a 0 in it then the Summed column will equal 0 showing that this piece of equipment cannot be used.

**Category:**

What number is placed next to deter, deny, detect, and defend for the ”Rank Importance of Following Categories” will be placed in this column for each piece of equipment that corresponds to each division of security. This is used as a weight and will be described later.

**Fire Department:**

If the fire department is more than 5 miles away then a 2 is placed in the column for the annunciator panel, infrared camera, flame detector, sprinkler system, and intumescent coating. This is done to give them a higher weight since these pieces of equipment either detect the fire quickly, defend the bridge after the fire has been started, or extinguish the fire. If the question “Is it a Volunteer Fire Department” is answered yes then 3 more miles are added to this total distance since there will be a longer response time.

**Maintenance:**

This column gives a high weight to maintenance if the user wants low maintenance

responsibility and a low weight if the user is indifferent to maintenance responsibility. All equipment is given a level of maintenance required from 1 as high and 4 as low. These numbers are then multiplied together giving a total weight for maintenance. An example is if the user does not want to maintain then a weight of 4 is given to maintenance. This will amplify maintenance by a factor of 4 within the importance factor which will be discussed later.

### **Arson:**

Much like maintenance, Arson is used as a weight to multiply the importance factor. If a 5 is chosen for “Probability of Arson” then a 5 will be placed within this column for all equipment. All equipment is then given a number between 1 and 4 with 1 meaning a low ability to protect against arson and 4 meaning a high ability to protect against arson.

### **Vandalism:**

Much like arson, Vandalism is used as a weight to multiply the importance factor. If a 5 is chosen for “Probability of Vandalism” then a 5 will be placed within this column for all equipment. All equipment is then given a number between 1 and 4 with 1 meaning a low ability to protect against vandalism and 4 meaning a high ability to protect against vandalism.

### **Total:**

This is the final column that is used for the importance factor. The total multiplies the Summed column with all other weight columns. The higher the number the more important the piece of equipment is to a security system. At the bottom of the column the highest number is calculated through excel functions. This is used later on in the Importance Factor.

Required Questions for Decision Making Tool		
<b>Instructions</b>		
All red fields must be answered correctly from dropdown menu		
Price Range	\$20,000	
Probability of Arson	(1) Low	3 (5) High
Probability of Vandalism	(1) Low	5 (5) High
Rank Importance of Following Categories (1) Low (4) High	1	Deter
	3	Deny
	2	Detect
	4	Defend
Maintenance Expected (1) Low (4) High	3	
Ability to Use Electrical Components	Yes	
Cost to Bring Electric to Site	\$100	
Ability to Use Water Hookup	Yes	
Cost to Bring Water to Site	\$100	
Current Equipment on Site	Annunciator Panel	No
	Interior Lighting	No
	Exterior Lighting	No
	Signage	No
	Decorative Planters	No
	Bollards	No
	Fencing	Yes
	Infrared Cameras	No
	Video Surveillance	No
	Heat Detector	No
	Smoke Detector	Yes
	Flame Detector	No
	Fiber Optic Sensor	No
	Fire Hydrant	No
	Sprinkler System	No
Intumescent Coating/ Fire Retardant Material	No	
Vehicles Allowed on Bridge	No	
Nearest Fire/Police Station	5	Miles
Is it a Volunteer Fire Department	Yes	
Ability to Use Fencing at Bridge Site	Yes	
Length of Fencing Required	100	Feet
Bridge Length	100	Feet
Bridge Width	20	Feet

Figure 72: User Interface for Decision Making Tool

Required Calculations for Decision Making Tool																			
#	Equipment	Price	Fencing	Electric	Water	Exist 1	Traffic	Summed	Category	Fire Dept	Maintenance	Arson	Vandalism	Total					
1	Annunciator Panel	\$300	1	1	1	1	1	1	1	2	2	4	3	9	3	15	1,080		
2	Interior Lighting	\$400	1	1	1	1	1	1	1	1	2	3	6	5	4	20	720		
3	Exterior Lighting	\$600	1	1	1	1	1	1	1	1	2	3	6	5	4	20	720		
4	(4) Signs	\$200	1	1	1	1	1	1	1	1	2	4	8	3	5	2	240		
5	Decorative Planters	\$600	1	1	1	1	1	1	3	1	2	4	8	3	5	2	720		
6	(4) Bollards	\$600	1	1	1	1	1	1	3	1	2	4	8	3	5	2	720		
7	Chain Link	\$800	1	1	1	0	1	0	3	1	2	4	8	3	5	3	15	0	
8	Wood Fence	\$1,000	1	1	1	0	1	0	3	1	2	3	6	3	5	3	15	0	
9	Wrough Iron	\$2,500	1	1	1	0	1	0	3	1	2	4	8	3	5	3	15	0	
10	Block Wall	\$6,000	1	1	1	0	1	0	3	1	2	4	8	3	5	3	15	0	
11	Infrared Camera	\$5,000	1	1	1	1	1	1	2	2	2	1	2	3	4	12	5	3	1,440
12	Video Surveillance	\$300	1	1	1	1	1	1	2	1	2	1	2	3	3	9	5	3	540
13	(2) Heat Detector	\$200	1	1	1	1	1	1	2	2	2	1	2	3	3	9	5	1	360
14	Smoke Detector	\$0	1	1	1	0	1	0	2	1	2	1	2	3	1	3	5	1	0
15	(2) Flame Detector	\$3,000	1	1	1	1	1	1	2	2	2	1	2	3	4	12	5	1	480
16	Fiber Optic Sensor	\$10,000	1	1	1	1	1	1	2	1	2	1	2	3	3	9	5	1	180
17	Fire Hydrant	\$3,000	1	1	1	1	1	1	4	1	2	3	6	3	9	5	1	5	1,080
18	Sprinkler System	\$15,000	0	1	1	1	1	1	4	2	2	2	4	3	4	12	5	1	0
19	Intumescent Coating	\$10,000	1	1	1	1	1	1	4	2	2	3	6	3	4	12	5	1	2,880
																			2,880

Figure 73: Required Calculations for Decision Making Tool

Final Recommendations for Security Systems on Covered Bridges									
#	Importance Factor	Equipment	Average Price	Price for Average Bridge	Installation Included	Average Capabilities	Main Drawbacks	*Requirements	Maintenance
1	0.3750	Annunciator Panel	\$300	\$300	No	Audible/Visible signals at structure Notify proper authorities	Possibility of false alarms at bridge site Can notify trespasser and allow escape	Low electrical draw Enclosure for	Monthly
2	0.2500	Interior Lighting	\$4/ft <sup>2</sup>	\$8,000	Yes	Make portions of bridge site visible day/night Allow cameras to see during low light levels		Moderate electrical draw	Yearly
3	0.2500	Exterior Lighting	\$80/fixture	\$600	No	Make portions of bridge site visible day/night Allow cameras to see during low light levels	Can lead to light pollution	Moderate electrical draw	Yearly
4	0.0833	(4) Signs	\$50	\$200	No	Inform trespassers of consequences			Rare
5	0.2500	Decorative Planters	\$300	\$600	No	Limit traffic to certain sized vehicles Stop traffic altogether from entering bridge	May be difficult to move when necessary		Rare
6	0.2500	(4) Bollards	\$150	\$600	No	Limit traffic to certain sized vehicles Stop traffic altogether from entering bridge	May be difficult to move when necessary		Rare
7	0.0000	Chain Link	\$8/foot	\$800	No	Limit access points at bridge site	Cannot completely limit access points		Rare
8	0.0000	Wood Fence	\$10/foot	\$1,000	No	Limit access points at bridge site	Rot and warping of wood may occur over time		Yearly
9	0.0000	Wrought Iron	\$25/foot	\$2,500	No	Limit access points at bridge site	Cannot completely limit access points		Rare
10	0.0000	Block Wall	**\$10/SF	\$6,000	Yes	Limit access points at bridge site	Cannot completely limit access points		Rare
11	0.5000	Infrared Camera	\$5,000	\$5,000	No	Monitor temperatures within field of view View bridge regardless of amount of light	False alarms due to glare, animals, or heat Sensitive to environment	High electrical draw Pole	Yearly
12	0.1875	Video Surveillance	\$300	\$300	No	View bridge during times of adequate light Allow remote parties to view bridge	Dependent on lighting in field of view	High electrical draw Pole	Yearly
13	0.1250	(2) Heat Detector	\$100	\$200	No	Monitor temperatures around detector	False alarms due to environment	Moderate electrical draw	Yearly
14	0.0000	Smoke Detector	\$50	\$0	No	Monitor smoke levels around detector	Highly vulnerable to exterior conditions	Low electrical draw	Monthly
15	0.1667	(2) Flame Detector	\$1,500	\$3,000	No	Monitor temperatures within field of view	False alarms due to glare, animals, or heat	Moderate electrical draw	Yearly
16	0.0625	Fiber Optic Sensor			No	Monitor temperatures along length of device	Possible difficult with installing	Moderate electrical draw	Yearly
17	0.3750	Fire Hydrant	\$3,000	\$3,000	Yes	Provide water source to fire department	Requires close water supply	Close water supply	Yearly
18	0.0000	Sprinkler System	\$15,000	\$15,000	Yes	Extinguish fires started within interior of bridge	Requires close water supply Bulky and not aesthetically pleasing	Close water supply	Yearly
19	1.0000	Intumescent Coating/ Fire Retardant Material	\$8/SF	\$10,000	Yes	Stop or slow the ignition of a fire Stop the spread of any fires that may start	Loss of effectiveness over time Loss of structural strength to applied	Close water supply	Every few years

Sort Importance Factor  
Sort Equipment #

**Further Recommendations**

Care should be taken to choose equipment from all color selections when designing a security system

Intumescent Coating and Fire Retardant Wood are interchangeable and depend on whether renovation or remodeling is planned

If equipment that requires electricity or water are used within the system the cost to bring water/electric to site should be subtracted from total price range

Deter
Deny
Detect
Defend

Figure 74: Recommendations Page of Decision Making Tool

An example is given with the decision making tool that shows how a bridge owner should fill out the questionnaire under certain bridge conditions. This example questionnaire can be seen in Figure 75 with all the proper fields filled in. The truncated results from this questionnaire can be seen in Figure 76. From these results an example budget is assembled that would show the logical and appropriate steps, which is shown in Figure 77. This example problem is intended to show the bridge owners how to correctly fill out the questionnaire and how to interpret the results.

Required Questions for Decision Making Tool		
<b>Instructions</b>		
All red fields must be answered correctly from dropdown menu		
Price Range	\$50,000	
Probability of Arson	(1) Low	4 (5) High
Probability of Vandalism	(1) Low	2 (5) High
Rank Importance of Following Categories (1) Low (4) High	2	Deter
	1	Deny
	3	Detect
	4	Defend
Maintenance Expected (1) Low (4) High	2	
Ability to Use Electrical Components	Yes	
Cost to Bring Electric to Site	\$500	
Ability to Use Water Hookup	No	
Cost to Bring Water to Site	\$500	
Current Equipment on Site	Annunciator Panel	No
	Interior Lighting	No
	Exterior Lighting	Yes
	Signage	Yes
	Decorative Planters	No
	Bollards	No
	Fencing	Yes
	Infrared Cameras	No
	Video Surveillance	No
	Heat Detector	No
	Smoke Detector	No
	Flame Detector	No
	Fiber Optic Sensor	No
	Fire Hydrant	No
Sprinkler System	No	
Intumescent Coating/ Fire Retardant Material	No	
Vehicles Allowed on Bridge	Yes	
Nearest Fire/Police Station	6	Miles
Is it a Volunteer Fire Department	Yes	
Ability to Use Fencing at Bridge Site	Yes	
Length of Fencing Required	100	Feet
Bridge Length	120	Feet
Bridge Width	15	Feet

Figure 75: Example Required Questions for Decision Making Tool

#	Importance Factor	Equipment	Price
19	1.0000	Intumescent Coating/ Fire Retardant Material	\$10,000
1	0.7500	Annunciator Panel	\$1,000
11	0.7500	Infrared Camera	\$5,000
2	0.5000	Interior Lighting	\$7,200
12	0.2813	Video Surveillance	\$300
15	0.2500	(2) Flame Detector	\$3,000
13	0.1875	(2) Heat Detector	\$200
16	0.0000	Fiber Optic Sensor	\$0
14	0.0000	Smoke Detector	\$0
18	0.0000	Sprinkler System	\$15,000
17	0.0000	Fire Hydrant	\$3,000
6	0.0000	(4) Bollards	\$600
4	0.0000	(4) Signs	\$200
3	0.0000	Exterior Lighting	\$600
5	0.0000	Decorative Planters	\$600
7	0.0000	Chain Link	\$800
8	0.0000	Wood Fence	\$1,000
9	0.0000	Wrough Iron	\$2,500
10	0.0000	Block Wall	\$6,000

Figure 76: Example Recommendations for Decision Making Tool



<b>Example Covered Bridge Definition:</b>	
It can be seen through the questionnaire that this bridge is located in a remote area (6 miles away and protected by a Volunteer Fire Department). Fencing and Exterior Lighting are already installed at the site to deter trespassers but the bridge owner has a budget of \$50,000 and wants to spend it on protecting the bridge against arson. One major limitation is that the bridge owner is not able to get water hook-ups to the bridge site at this time.	
<b>Example Covered Bridge Planned Budget:</b>	
<b>Price:</b>	<b>Equipment:</b>
\$10,000	Intumescent Coating: Fire Retardant Wood was not decided upon because there are not any plans for future renovation or remodeling on this bridge. Intumescent Coating was given the Importance Factor of 1.0 meaning that it will be the most beneficiary to this bridge and it's security requirements
\$500	Cost to Bring Electric to Site: Since electrical devices will be used within this security system it is required to subtract this cost from your total budget.
\$1,000	Annunciator Panel/Communication Devices: An Annunciator Panel will allow for information to be sent out wirelessly that is detected through other pieces of equipment such as cameras or detectors. Given the remote environment that this bridge is in the owner has decided to choose an annunciator panel that will emit noise and sound when a danger is detected to deter any trespassers of continuing any more damage to the bridge.
\$5,000	Infrared Camera: An Infrared Camera will work with the Annunciator Panel and Communication Devices to send out any detections to local city officials such as the fire department and police. The infrared camera will be able to detect a fire or any temperatures that exceed it's threshold. An Infrared Camera also gives the security system the ability to view the bridge at night or times of low light.
\$7,200	Interior Lighting: This bridge already had lighting on the exterior of the bridge but by placing lighting on the interior the security system will heighten the deterrence factor and lessen the chance that a fire will be started in the interior of the bridge. The Infrared Camera will already be detecting the exterior of the bridge for any fire or areas of high temperature.
\$0	Video Surveillance: Although Video Surveillance has the next highest importance factor it was decided that they should not be used for this project. The addition of surveillance cameras would add redundancy to the system but would also require increased maintenance and continual cost from electrical draw. This will be discussed in the Notes portion of this example.
\$3,000	(2) Flame Detectors Placing flame detectors at both ends of the covered bridge will detect any fires that are started within the bridge. This will work with the Annunciator Panel/Communication Devices to send out an alarm, much like the Infrared Camera, if any fire is detected.
\$0	Heat Detector Heat Detectors will not used on this bridge, much like the video surveillance, because the Flame Detectors and Infrared Cameras already protect the bridge in the way that the Heat Detectors would. This would add redundancy but once again will also add increased maintenance and continual cost from electrical draw.
\$26,700	<b>Total Cost</b> This total cost is almost half of the intended budget so the bridge owner decides to add value to some of the equipment that will be installed. It is decided to upgrade the Infrared Camera and Flame Detectors since they are essential in protecting against arson.
\$10,000	Added to Infrared Camera This will bring the total of the Infrared Camera up to \$15,000.
\$4,000	Added to Flame Detectors This will bring the total of the Flame Detectors to \$7,000.
\$40,700	<b>New Total Cost</b>
<b>Notes:</b>	
The owner will still have \$9,300 for unforeseen costs and possible additions such as video surveillance or heat detectors if there are flaws in the security system after initial set-up	
This excess money will also be required for installation since installation is only included in the price for interior lighting. These prices will vary depending on the equipment and man power available to the bridge owner.	
It is important for the bridge owner to realize that a charge will be incurred through the electric hook-up as long as the system is running. This charge can come out of this excess money or already be budgeted long term. This is something that must be decided in the initial stages of the security system design.	

**Figure 77: Example Budget for Decision Making Tool**

## APPENDIX C NCBPPA BUDGET

Table 3: NHCBPPA Budget Breakdown by State

Year	State	Bridge Name	Cost
2000	AL	Clarkson/Legg Covered Bridge	\$400,000.00
2006	AL	Easley Covered Bridge	\$40,899.00
2006	AL	Horton Mill Covered Bridge	\$96,777.00
2006	AL	Swann Covered Bridge	\$68,787.00
2009	AL	Alamuchee Covered Bridge	\$20,474.11
		<b>Alabama Total</b>	<b>\$626,937.11</b>
2001	CA	Wawona Covered Bridge	165,000.00
2003	CA	Wawona Covered Bridge	\$276,166.00
		<b>California Total</b>	<b>\$441,166.00</b>
2000	CT	Comstock Covered Bridge	\$84,800.00
2003	CT	Cornstock Covered Bridge	\$340,000.00
2007	CT	Comstock Covered Bridge	\$1,460,000.00
		<b>Connecticut Total</b>	<b>\$1,884,800.00</b>
2001	DE	Ashland Covered Bridge	155,000.00
2001	DE	Wooddale Covered Bridge	155,000.00
		<b>Delaware Total</b>	<b>310,000.00</b>
2000	IA	Imes Covered Bridge	\$733.33
2000	IA	Cutler Donahoe Covered Bridge	\$733.33
2000	IA	Hogback Covered Bridge	\$733.33
2000	IA	Holliwell Covered Bridge	\$733.33
2000	IA	Roseman Covered Bridge	\$733.33
2000	IA	Cedar Covered Bridge	\$733.33
2002	IA	Hammond Covered Bridge	\$176,000.00
2003	IA	Delta Covered Bridge	\$150,000.00
2007	IA	Roseman Covered Bridge	\$75,152.00
2007	IA	Holliwell Covered Bridge	\$75,152.00
2007	IA	Hogback Covered Bridge	\$75,152.00
2007	IA	Imes Covered Bridge	\$75,152.00
2007	IA	Cutler Donahoe Covered Bridge	\$75,152.00
		<b>Iowa Total</b>	<b>\$706,159.98</b>
2000	IL	Thompson Mill Covered Bridge	\$96,000.00
2001	IL	Sugar Creek Covered Bridge	96,000.00

2001	IL	Red Covered Bridge	96,000.00
2001	IL	Oquawka Wagon Covered Bridge	96,000.00
2002	IL	Little Mary's River Covered Bridge	\$461,830.00
2003	IL	Little Mary's River Covered Bridge	\$57,947.00
2003	IL	Red Covered Bridge	\$57,947.00
2003	IL	Sugar Creek Covered Bridge	\$57,947.00
2003	IL	Thompson Mill Covered Bridge	\$57,947.00
2003	IL	Oquawka Wagon Covered Bridge	\$57,947.00
2007	IL	Sugar Creek Covered Bridge	\$120,000.00
2007	IL	Thompson Mill Covered Bridge	\$80,400.00
2008	IL	Oquawka Wagon Covered Bridge	\$68,000.00
2009	IL	Thompson Mill Covered Bridge	\$8,000.00
		<b>Illinois Total</b>	<b>\$1,411,965.00</b>
2000	IN	Norris Ford Covered Bridge	\$200,000.00
2000	IN	State Sanatorium Covered Bridge	\$600,000.00
2000	IN	Snow Hill Covered Bridge	\$100,000.00
2000	IN	Medora Covered Bridge	\$69,600.00
2001	IN	Ramp Creek Covered Bridge	58,000.00
2001	IN	Bell Ford Covered Bridge	180,000.00
2001	IN	James Covered Bridge	80,000.00
2001	IN	Scipio Covered Bridge	65,000.00
2001	IN	Deers Mill Covered Bridge	75,000.00
2001	IN	Cataract Falls Covered Bridge	70,000.00
2001	IN	Narrows Covered Bridge	179,000.00
2001	IN	Cedar Ford Covered Bridge	100,000.00
2003	IN	Lancaster Covered Bridge	\$233,600.00
2006	IN	Bell Ford Covered Bridge	\$448,000.00
2006	IN	Medora Covered Bridge	\$880,000.00
2006	IN	North Manchester Covered Bridge	\$592,000.00
2006	IN	Santorium Covered Bridge	\$497,053.00
2006	IN	Shieldstown Covered Bridge	\$680,000.00
2006	IN	James Covered Bridge	\$256,000.00
2006	IN	Scipio Covered Bridge	\$240,000.00
2007	IN	Cedar Ford Covered Bridge	\$712,000.00
2007	IN	Huffman Covered Bridge	\$240,000.00
2008	IN	Snow Hill Covered Bridge	\$376,500.00
2009	IN	Huffman Covered Bridge	\$991,680.00

		<b>Indiana Total</b>	<b>\$7,923,433.00</b>
2000	KT	Bennett's Mill Covered Bridge	\$600,000.00
2001	KT	Johnson Creek Covered Bridge	643,432.00
2001	KT	Goddard Covered Bridge	464,640.00
2007	KT	Johnson Creek Covered Bridge	\$319,104.00
2007	KT	Cabin Creek Covered Bridge	\$503,904.00
2007	KT	Beech Fork Covered Bridge	\$288,842.00
		<b>Kentucky Total</b>	<b>\$2,819,922.00</b>
2001	MA	Burkeville Covered Bridge	352,000.00
2002	MA	Colrain Covered Bridge	\$461,830.00
2003	MA	Hardwick/Ware, Gilvertville Covered Bridge	\$340,000.00
		<b>Massachusetts Total</b>	<b>\$1,153,830.00</b>
2007	MD	Gilpin Falls Covered Bridge	\$1,040,000.00
2009	MD	Jericho Road Covered Bridge	\$1,328,000.00
		<b>Maryland Total</b>	<b>\$2,368,000.00</b>
2000	ME	Bennett's Mill Covered Bridge	\$581,404.00
2001	ME	Watson Covered Bridge	840,400.00
		<b>Maine Total</b>	<b>1,421,804.00</b>
2003	MO	Bunfordville Covered Bridge	\$99,556.00
2003	MO	Union Covered Bridge	\$41,250.00
2003	MO	Locust Creek Covered Bridge	\$18,368.00
		<b>Missouri Total</b>	<b>\$159,174.00</b>
2001	NH	Cornish Windsor Covered Bridge	140,000.00
2001	NH	Honeymoon Covered Bridge	64,000.00
2001	NH	The County Covered Bridge	36,000.00
2001	NH	The Saco River Covered Bridge	140,000.00
2002	NH	Honeymoon Bridge	\$461,830.00
2003	NH	Honeymoon Bridge	\$248,000.00
2006	NH	Thompson Covered Bridge	\$344,000.00
2007	NH	Whittier Covered Bridge	\$632,000.00
2008	NH	Bath Village Covered Bridge	\$2,320,000.00
2009	NH	Blair Covered Bridge	\$1,724,000.00
		<b>New Hampshire Total</b>	<b>\$6,109,830.00</b>
2000	NY	Fitches Covered Bridge	\$267,000.00
2001	NY	Copeland Covered Bridge	74,000.00
2001	NY	Eagleville Road Covered Bridge	93,200.00

2001	NY	Rexleigh Road Covered Bridge	106,800.00
2002	NY	Salisbury Center Covered Bridge	\$153,500.00
2003	NY	Jay Covered Bridge	\$340,000.00
2007	NY	Newfield Covered Bridge	\$88,000.00
2008	NY	Beaverkill Covered Bridge	\$72,000.00
		<b>New York Total</b>	<b>\$1,194,500.00</b>
2000	OH	Eakin Mill Covered Bridge	\$500,000.00
2000	OH	Ponn Covered Bridge	\$400,000.00
2000	OH	Hills Covered Bridge	\$107,236.00
2000	OH	Teegarden-Centennial Covered Bridge	\$200,000.00
2001	OH	Byer Covered Bridge	284,342.00
2001	OH	Brown Covered Bridge	192,000.00
2001	OH	Parrish Covered Bridge	192,000.00
2001	OH	Manchester Covered Bridge	120,000.00
2001	OH	Brubaker Covered Bridge	35,200.00
2001	OH	New Hope Covered Bridge	220,000.00
2003	OH	Eldean Covered Bridge	\$340,000.00
2006	OH	Stonelick Covered Bridge	\$360,000.00
2007	OH	Pottersburg Covered Bridge	\$34,533.33
2007	OH	Axe Handle Road Covered Bridge	\$34,533.33
2007	OH	Spain Creek Covered Bridge	\$34,533.33
2007	OH	Culbertson Covered Bridge	\$34,533.33
2008	OH	West Engle Mill Covered Bridge	\$425,681.00
2008	OH	Eldean Covered Bridge	\$16,000.00
2009	OH	West Engle Mill Covered Bridge	\$246,319.00
2009	OH	Stonelick Creek Covered Bridge	\$240,000.00
2009	OH	Harshaville Covered Bridge	\$100,000.00
		<b>Ohio Total</b>	<b>\$4,116,911.32</b>
2000	OR	Fisher School Covered Bridge	\$300,000.00
2001	OR	Wimer Covered Bridge	528,480.00
2001	OR	Mary's River & Hayden Road Covered	104,000.00
2001	OR	Horse Creek Covered Bridge	35,000.00
2003	OR	Ritner Creek Covered Bridge	\$339,360.00
2006	OR	Cavitt Creek Covered Bridge	\$125,622.00
2006	OR	Gallon House Covered Bridge	\$106,778.00
2006	OR	Hannah Covered Bridge	\$696,900.00
2006	OR	Hoffman Covered Bridge	\$685,200.00

2006	OR	Neal Lane Covered Bridge	\$108,574.00
2006	OR	Parvin Covered Bridge	\$733,722.00
2006	OR	Rochester Covered Bridge	\$157,925.00
2006	OR	Short Covered Bridge	\$102,000.00
2007	OR	Good Pasture Covered Bridge	\$181,270.00
2007	OR	Irish Bend Covered Bridge	\$56,081.00
2007	OR	Pass Creek Covered Bridge	\$49,800.00
2008	OR	Chambers Railroad Bridge	\$1,315,370.00
2008	OR	Chtwood Covered Bridge	\$1,076,760.00
2008	OR	N. Fk. Yachats River Covered Bridge	\$596,704.00
2008	OR	Gallon House Covered Bridge	\$51,147.00
2008	OR	Nelson Mountain Covered Bridge	\$17,946.00
2008	OR	Mosby Creek (Layng) Covered Bridge	\$17,946.00
2008	OR	Pengra Covered Bridge	\$17,946.00
2009	OR	Layng Covered Bridge	\$897,300.00
2009	OR	Deadwood Covered Bridge	\$181,270.00
		<b>Oregon Total</b>	<b>\$8,483,101.00</b>
2000	PA	Knapps Covered Bridge	\$90,000.00
2000	PA	Patterson Covered Bridge	\$100,000.00
2001	PA	Kramer Covered Bridge	260,000.00
2001	PA	Hillsgrove Covered Bridge	360,000.00
2003	PA	King's Covered Bridge	\$340,000.00
2006	PA	Patterson Covered Bridge	\$50,000.00
2006	PA	Speakman Covered Bridge	\$1,442,400.00
2007	PA	Shoemaker Covered Bridge	\$356,000.00
2007	PA	Academia Covered Bridge	\$48,000.00
2007	PA	Kreidersville Covered Bridge	\$19,023.00
2007	PA	Moreland Covered Bridge	\$640,000.00
2007	PA	Cox Farm Covered Bridge	\$152,000.00
2007	PA	Shriver Covered Bridge	\$152,000.00
2009	PA	Rudolph and Arthur Covered Bridge	\$1,600,000.00
2009	PA	Kauffman's Distillery Covered Bridge	\$65,600.00
		<b>Pennsylvania Total</b>	<b>\$5,675,023.00</b>
2001	TN	Harrisburg Covered Bridge	96,392.00
2002	TN	Harrisburg Covered Bridge	\$371,760.00
2007	TN	Elizabethton Covered Bridge	\$320,000.00

		<b>Tennessee Total</b>	<b>\$788,152.00</b>
2000	VA	Meems Bottom Covered Bridge	\$40,000.00
2003	VA	Meems Bottom Covered Bridge	\$30,400.00
2007	VA	Jack Creek Covered Bridge	\$220,000.00
2009	VA	Humpback Covered Bridge	\$1,005,000.00
		<b>Virginia Total</b>	<b>\$1,295,400.00</b>
2000	VT	Sanderson Covered Bridge	\$450,000.00
2000	VT	Greenbanks Hollow Covered Bridge	\$300,000.00
2001	VT	Comstock Covered Bridge	576,000.00
2001	VT	Cooley Covered Bridge	200,000.00
2001	VT	Gorham Covered Bridge	576,000.00
2001	VT	38 Covered Bridges Statewide	461,600.00
2001	VT	Thetford (Sayres) Covered Bridge	24,000.00
2002	VT	Grist Mill Canyon Covered Bridge	\$336,000.00
2003	VT	Weathersfield Upper Falls Covered Bridge	\$596,100.00
2003	VT	Tunbridge Cilley Covered Bridge	\$317,920.00
2003	VT	Salisbury-Cornwall Covered Bridge	\$397,400.00
2003	VT	Thetford Sayre Covered Bridge	\$675,580.00
2006	VT	Salisbury-Cornwall Covered Bridge	\$773,510.00
2006	VT	Thetford Sayre Covered Bridge	\$206,584.00
2006	VT	Weathersfield Upper Falls Covered Bridge	\$278,720.00
2007	VT	River Road Covered Bridge	\$200,000.00
2007	VT	Braley Covered Bridge	\$200,000.00
2007	VT	Willard Covered Bridge	\$150,000.00
2008	VT	Hutchins Covered Bridge	\$1,000,000.00
2008	VT	West Hill Creamery Covered Bridge	\$435,000.00
2008	VT	Worral Covered Bridge	\$500,000.00
2009	VT	Taftsville Covered Bridge	\$100,000.00
		<b>Vermont Total</b>	<b>\$8,754,414.00</b>
2002	WA	City of Pe Ell's Tin Bridge	\$400,000.00
2006	WA	Grays River	\$112,000.00
		<b>Washington Total</b>	<b>\$512,000.00</b>
2000	WV	Fletcher Covered Bridge	\$500,000.00
2000	WV	Hokes Mill Covered Bridge	\$450,000.00
2000	WV	Simpson Creek Covered Bridge	\$300,000.00
2000	WV	Locust Creek Covered Bridge	\$259,560.00

2001	WV	Walkersville Covered Bridge	260,000.00
2003	WV	Dents Run Covered Bridge	\$195,000.00
		<b>West Virginia Total</b>	<b>\$1,964,560.00</b>

**Table 4: NHCBPPA Budget Breakdown by Year**

<b>Year</b>	<b>State</b>	<b>Bridge Name</b>	<b>Cost</b>
2000	AL	Clarkson/Legg Covered Bridge	\$400,000.00
2000	CT	Comstock Covered Bridge	\$84,800.00
2000	IA	Imes Covered Bridge	\$733.33
2000	IA	Cutler Donahoe Covered Bridge	\$733.33
2000	IA	Hogback Covered Bridge	\$733.33
2000	IA	Holliwell Covered Bridge	\$733.33
2000	IA	Roseman Covered Bridge	\$733.33
2000	IA	Cedar Covered Bridge	\$733.33
2000	IL	Thompson Mill Covered Bridge	\$96,000.00
2000	IN	Norris Ford Covered Bridge	\$200,000.00
2000	IN	State Sanatorium Covered Bridge	\$600,000.00
2000	IN	Snow Hill Covered Bridge	\$100,000.00
2000	IN	Medora Covered Bridge	\$69,600.00
2000	KT	Bennett's Mill Covered Bridge	\$600,000.00
2000	ME	Bennett's Mill Covered Bridge	\$581,404.00
2000	NY	Fitches Covered Bridge	\$267,000.00
2000	OH	Eakin Mill Covered Bridge	\$500,000.00
2000	OH	Ponn Covered Bridge	\$400,000.00
2000	OH	Hills Covered Bridge	\$107,236.00
2000	OH	Teegarden-Centennial Covered Bridge	\$200,000.00
2000	OR	Fisher School Covered Bridge	\$300,000.00
2000	PA	Knapps Covered Bridge	\$90,000.00
2000	PA	Patterson Covered Bridge	\$100,000.00
2000	VA	Meems Bottom Covered Bridge	\$40,000.00
2000	VT	Sanderson Covered Bridge	\$450,000.00
2000	VT	Greenbanks Hollow Covered Bridge	\$300,000.00
2000	WV	Fletcher Covered Bridge	\$500,000.00
2000	WV	Hokes Mill Covered Bridge	\$450,000.00
2000	WV	Simpson Creek Covered Bridge	\$300,000.00



2000	WV	Locust Creek Covered Bridge	\$259,560.00
		<b>2000 Total</b>	<b>\$6,999,999.98</b>
2001	CA	Wawona Covered Bridge	165,000.00
2001	DE	Ashland Covered Bridge	155,000.00
2001	DE	Wooddale Covered Bridge	155,000.00
2001	IL	Sugar Creek Covered Bridge	96,000.00
2001	IL	Red Covered Bridge	96,000.00
2001	IL	Oquawka Wagon Covered Bridge	96,000.00
2001	IN	Ramp Creek Covered Bridge	58,000.00
2001	IN	Bell Ford Covered Bridge	180,000.00
2001	IN	James Covered Bridge	80,000.00
2001	IN	Scipio Covered Bridge	65,000.00
2001	IN	Deers Mill Covered Bridge	75,000.00
2001	IN	Cataract Falls Covered Bridge	70,000.00
2001	IN	Narrows Covered Bridge	179,000.00
2001	IN	Cedar Ford Covered Bridge	100,000.00
2001	KT	Johnson Creek Covered Bridge	643,432.00
2001	KT	Goddard Covered Bridge	464,640.00
2001	MA	Burkeville Covered Bridge	352,000.00
2001	ME	Watson Covered Bridge	840,400.00
2001	NH	Cornish Windsor Covered Bridge	140,000.00
2001	NH	Honeymoon Covered Bridge	64,000.00
2001	NH	The County Covered Bridge	36,000.00
2001	NH	The Saco River Covered Bridge	140,000.00
2001	NY	Copeland Covered Bridge	74,000.00
2001	NY	Eagleville Road Covered Bridge	93,200.00
2001	NY	Rexleigh Road Covered Bridge	106,800.00
2001	OH	Byer Covered Bridge	284,342.00
2001	OH	Brown Covered Bridge	192,000.00
2001	OH	Parrish Covered Bridge	192,000.00
2001	OH	Manchester Covered Bridge	120,000.00
2001	OH	Brubaker Covered Bridge	35,200.00
2001	OH	New Hope Covered Bridge	220,000.00
2001	OR	Wimer Covered Bridge	528,480.00
2001	OR	Mary's River & Hayden Road Covered	104,000.00
2001	OR	Horse Creek Covered Bridge	35,000.00

2001	PA	Kramer Covered Bridge	260,000.00
2001	PA	Hillsgrove Covered Bridge	360,000.00
2001	TN	Harrisburg Covered Bridge	96,392.00
2001	VT	Comstock Covered Bridge	576,000.00
2001	VT	Cooley Covered Bridge	200,000.00
2001	VT	Gorham Covered Bridge	576,000.00
2001	VT	38 Covered Bridges Statewide	461,600.00
2001	VT	Thetford (Sayres) Covered Bridge	24,000.00
2001	WV	Walkersville Covered Bridge	260,000.00
		<b>2001 Total</b>	<b>9,049,486.00</b>
2002	IA	Hammond Covered Bridge	\$176,000.00
2002	IL	Little Mary's River Covered Bridge	\$461,830.00
2002	MA	Colrain Covered Bridge	\$461,830.00
2002	NH	Honeymoon Bridge	\$461,830.00
2002	NY	Salisbury Center Covered Bridge	\$153,500.00
2002	TN	Harrisburg Covered Bridge	\$371,760.00
2002	VT	Grist Mill Canyon Covered Bridge	\$336,000.00
2002	WA	City of Pe Ell's Tin Bridge	\$400,000.00
		<b>2002 Total</b>	<b>\$2,822,750.00</b>
2003	CA	Wawona Covered Bridge	\$276,166.00
2003	CT	Cornstock Covered Bridge	\$340,000.00
2003	IA	Delta Covered Bridge	\$150,000.00
2003	IL	Little Mary's River Covered Bridge	\$57,947.00
2003	IL	Red Covered Bridge	\$57,947.00
2003	IL	Sugar Creek Covered Bridge	\$57,947.00
2003	IL	Thompson Mill Covered Bridge	\$57,947.00
2003	IL	Oquawka Wagon Covered Bridge	\$57,947.00
2003	IN	Lancaster Covered Bridge	\$233,600.00
2003	MA	Hardwick/Ware, Gilvertville Covered Bridge	\$340,000.00
2003	MO	Bunfordville Covered Bridge	\$99,556.00
2003	MO	Union Covered Bridge	\$41,250.00
2003	MO	Locust Creek Covered Bridge	\$18,368.00
2003	NH	Honeymoon Bridge	\$248,000.00
2003	NY	Jay Covered Bridge	\$340,000.00
2003	OH	Eldean Covered Bridge	\$340,000.00
2003	OR	Ritner Creek Covered Bridge	\$339,360.00
2003	PA	King's Covered Bridge	\$340,000.00

2003	VA	Meems Bottom Covered Bridge	\$30,400.00
2003	VT	Weathersfield Upper Falls Covered Bridge	\$596,100.00
2003	VT	Tunbridge Cilley Covered Bridge	\$317,920.00
2003	VT	Salisbury-Cornwall Covered Bridge	\$397,400.00
2003	VT	Thetford Sayre Covered Bridge	\$675,580.00
2003	WV	Dents Run Covered Bridge	\$195,000.00
		<b>2003 Total</b>	<b>\$5,608,435.00</b>
2006	AL	Easley Covered Bridge	\$40,899.00
2006	AL	Horton Mill Covered Bridge	\$96,777.00
2006	AL	Swann Covered Bridge	\$68,787.00
2006	IN	Bell Ford Covered Bridge	\$448,000.00
2006	IN	Medora Covered Bridge	\$880,000.00
2006	IN	North Manchester Covered Bridge	\$592,000.00
2006	IN	Santorium Covered Bridge	\$497,053.00
2006	IN	Shieldstown Covered Bridge	\$680,000.00
2006	IN	James Covered Bridge	\$256,000.00
2006	IN	Scipio Covered Bridge	\$240,000.00
2006	NH	Thompson Covered Bridge	\$344,000.00
2006	OH	Stonelick Covered Bridge	\$360,000.00
2006	OR	Cavitt Creek Covered Bridge	\$125,622.00
2006	OR	Gallon House Covered Bridge	\$106,778.00
2006	OR	Hannah Covered Bridge	\$696,900.00
2006	OR	Hoffman Covered Bridge	\$685,200.00
2006	OR	Neal Lane Covered Bridge	\$108,574.00
2006	OR	Parvin Covered Bridge	\$733,722.00
2006	OR	Rochester Covered Bridge	\$157,925.00
2006	OR	Short Covered Bridge	\$102,000.00
2006	PA	Patterson Covered Bridge	\$50,000.00
2006	PA	Speakman Covered Bridge	\$1,442,400.00
2006	VT	Salisbury-Cornwall Covered Bridge	\$773,510.00
2006	VT	Thetford Sayre Covered Bridge	\$206,584.00
2006	VT	Weathersfield Upper Falls Covered Bridge	\$278,720.00
2006	WA	Grays River	\$112,000.00
		<b>2006 Total</b>	<b>\$10,083,451.00</b>
2007	CT	Comstock Covered Bridge	\$1,460,000.00
2007	IA	Roseman Covered Bridge	\$75,152.00
2007	IA	Holliwell Covered Bridge	\$75,152.00

2007	IA	Hogback Covered Bridge	\$75,152.00
2007	IA	Imes Covered Bridge	\$75,152.00
2007	IA	Cutler Donahoe Covered Bridge	\$75,152.00
2007	IL	Sugar Creek Covered Bridge	\$120,000.00
2007	IL	Thompson Mill Covered Bridge	\$80,400.00
2007	IN	Cedar Ford Covered Bridge	\$712,000.00
2007	IN	Huffman Covered Bridge	\$240,000.00
2007	KT	Johnson Creek Covered Bridge	\$319,104.00
2007	KT	Cabin Creek Covered Bridge	\$503,904.00
2007	KT	Beech Fork Covered Bridge	\$288,842.00
2007	MD	Gilpin Falls Covered Bridge	\$1,040,000.00
2007	NH	Whittier Covered Bridge	\$632,000.00
2007	NY	Newfield Covered Bridge	\$88,000.00
2007	OH	Pottersburg Covered Bridge	\$34,533.33
2007	OH	Axe Handle Road Covered Bridge	\$34,533.33
2007	OH	Spain Creek Covered Bridge	\$34,533.33
2007	OH	Culbertson Covered Bridge	\$34,533.33
2007	OR	Good Pasture Covered Bridge	\$181,270.00
2007	OR	Irish Bend Covered Bridge	\$56,081.00
2007	OR	Pass Creek Covered Bridge	\$49,800.00
2007	PA	Shoemaker Covered Bridge	\$356,000.00
2007	PA	Academia Covered Bridge	\$48,000.00
2007	PA	Kreidersville Covered Bridge	\$19,023.00
2007	PA	Moreland Covered Bridge	\$640,000.00
2007	PA	Cox Farm Covered Bridge	\$152,000.00
2007	PA	Shriver Covered Bridge	\$152,000.00
2007	TN	Elizabethton Covered Bridge	\$320,000.00
2007	VA	Jack Creek Covered Bridge	\$220,000.00
2007	VT	River Road Covered Bridge	\$200,000.00
2007	VT	Braley Covered Bridge	\$200,000.00
2007	VT	Willard Covered Bridge	\$150,000.00
		<b>2007 Total</b>	<b>\$8,742,317.32</b>
2008	IL	Oquawka Wagon Covered Bridge	\$68,000.00
2008	IN	Snow Hill Covered Bridge	\$376,500.00
2008	NH	Bath Village Covered Bridge	\$2,320,000.00
2008	NY	Beaverkill Covered Bridge	\$72,000.00
2008	OH	West Engle Mill Covered Bridge	\$425,681.00

2008	OH	Eldean Covered Bridge	\$16,000.00
2008	OR	Chambers Railroad Bridge	\$1,315,370.00
2008	OR	Chtwood Covered Bridge	\$1,076,760.00
2008	OR	N. Fk. Yachats River Covered Bridge	\$596,704.00
2008	OR	Gallon House Covered Bridge	\$51,147.00
2008	OR	Nelson Mountain Covered Bridge	\$17,946.00
2008	OR	Mosby Creek (Layng) Covered Bridge	\$17,946.00
2008	OR	Pengra Covered Bridge	\$17,946.00
2008	VT	Hutchins Covered Bridge	\$1,000,000.00
2008	VT	West Hill Creamery Covered Bridge	\$435,000.00
2008	VT	Worrall Covered Bridge	\$500,000.00
		<b>2008 Total</b>	<b>\$8,307,000.00</b>
2009	AL	Alamuchee Covered Bridge	\$20,474.11
2009	IL	Thompson Mill Covered Bridge	\$8,000.00
2009	IN	Huffman Covered Bridge	\$991,680.00
2009	MD	Jericho Road Covered Bridge	\$1,328,000.00
2009	NH	Blair Covered Bridge	\$1,724,000.00
2009	OH	West Engle Mill Covered Bridge	\$246,319.00
2009	OH	Stonelick Creek Covered Bridge	\$240,000.00
2009	OH	Harshaville Covered Bridge	\$100,000.00
2009	OR	Layng Covered Bridge	\$897,300.00
2009	OR	Deadwood Covered Bridge	\$181,270.00
2009	PA	Rudolph and Arthur Covered Bridge	\$1,600,000.00
2009	PA	Kauffman's Distillery Covered Bridge	\$65,600.00
2009	VA	Humpback Covered Bridge	\$1,005,000.00
2009	VT	Taftsville Covered Bridge	\$100,000.00
		<b>2009 Total</b>	<b>\$8,507,643.11</b>
		<b>2000-2009 Total</b>	<b>\$60,121,082.41</b>

## APPENDIX D MADISON PROJECT EQUIPMENT SPECIFICATIONS

# SS4-A Multi-Spectrum Electro-Optical Digital Fire Detector

# SS4-A



### FEATURES

- Multi-Spectrum™: senses ultraviolet, visible and Wide Band Infrared™
- Built-in Test for optical "through the lens" testing
- False alarm immunity
- Detects hydrocarbon and non-hydrocarbon based fires
- Wide field-of-view and solar-blind
- Adjustable detector sensitivity
- Microprocessor based algorithms: FirePic™, and Tri-Mode Plot™
- Wide temperature range of operation
- Compatible with standard approved fire alarm panels
- Explosion-Proof housing
- Time programmable alarm verification

### APPLICATIONS INCLUDE:

- Petrochemical Facilities and Refineries
- Co-Generation Plants
- Aircraft Hangars
- Silane Gas Storage
- Gas Turbines & Power Plants
- Gas Compressor Stations

The model SS4-A represents the world's pre-eminent UV/IR technology for Electro-Optical Flame Detectors with tens of thousands successfully operating in a multitude of installations worldwide. This Multi-Spectrum Detector senses radiant energy in the ultraviolet (UV), visible, and Wide Band Infrared™ (IR) spectrum. The radiant energy from all types of flaming fires will alert the detector to their presence.

The field of view is the widest in the industry with a 120 degree cone of vision. This means more hazard area can be covered by each detector. Greater sensitivity also increases the volume covered by each detector, up to four times more than some other detectors.

Using sophisticated microprocessor signal processing algorithms with complete spectrum information, virtual immunity to false alarms from arc welding, corona discharge and other common UV sources is achieved.

### OPERATION

The SS4 operates from standard 24 Volt DC power and interfaces to approved fire alarm panels or standard PLC's. When power is applied, a self test is performed and the fault relay resets to show no faults. The detector is then in normal operation. The front LEDs flash every ten seconds to indicate power is on.

The continuous spectral data stream of information from the sensor array is analyzed by the microprocessor. On Alarm, the detector activates the alarm relay and stores all of the pre-fire spectral data from the sensor array in non-volatile memory for retrieval and evaluation. This Fire Pic™ data can be used to postulate the cause of the fire.

As part of the FS2000™ System, the SS4-A detector communicates with CM1-A Controller via a four wire bi-directional RS-485 FireBus™.

Tri-Mode Plot Shown on Computer Display

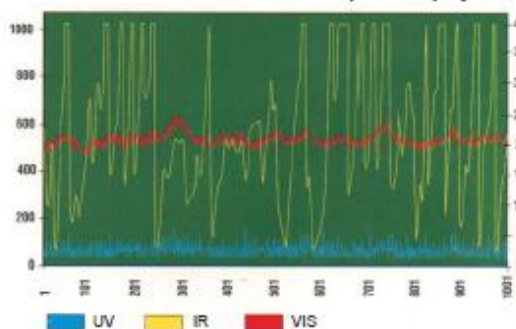

**WORLD LEADER IN ELECTRO-OPTICAL FIRE DETECTION TECHNOLOGY**



**FIRE SENTRY CORPORATION**



CSFM



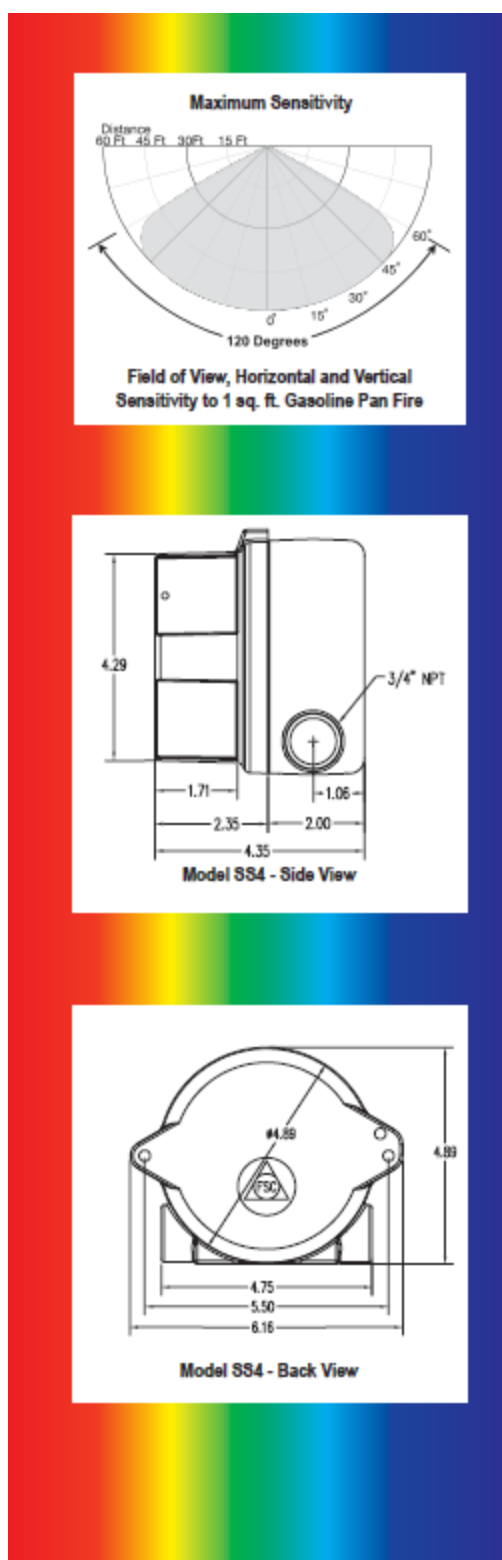

## SPECIFICATIONS

<b>Sensitivity</b>	Adjustable between 60 ft., 45 ft., 30 ft., & 15 ft. to a 1 sq. ft. gasoline fire
<b>Response Time</b>	2-5 seconds to 1 sq. ft. of gasoline fire at 60 ft.
<b>Field-of-View</b>	120 degrees cone of vision (60 degrees from on axis).
<b>Spectral Sensitivity</b>	Ultraviolet: 185 to 260 nanometers Wide Band Infrared: 0.7 to 3.5 micrometers Visible: 400 to 700 nanometers
<b>Input Power</b>	24 VDC nominal (20.5 to 34 VDC)
<b>Power Consumption</b>	68 mA normal operation (relay version) 75 mA alarm condition (relay version) 95 mA alarm condition (analog version)
<b>Relay Outputs</b>	<b>Fire Alarm relay:</b> NO & NC contacts Latching /Non-Latching, switch selectable <b>Fire Verify relay:</b> NO & NC contacts Adjustable time from 0 to 30 seconds <b>Fault relay:</b> NO & NC contacts Relay contact ratings: 0.5A at 120 VAC, 1.0A at 24 VDC Fault relay is energized during normal operation. All other relays are de-energized.
<b>Operating Temperature</b>	-40 to +185°F -40 to +85°C
<b>Humidity Range</b>	10 to 90% RH, non-condensing
<b>Weight</b>	4 pounds - Aluminum 7.5 pounds - Stainless Steel
<b>Housing</b>	Copper-free aluminum (less than 0.4% powder coated NEMA4 (IP66), tamper resistant with integral dual 3/4" NPT conduit openings, or optional M25, Stainless steel housing available.
<b>Electrical Classification</b>	Explosion-Proof Class I, Div. 1 & 2, Groups B, C, & D Class II, Div. 1 & 2, Groups E, F, & G Class III.
<b>Vibration</b>	Meets or exceeds Mil Spec 810C Method 514.2, Curve AW
<b>Mounting</b>	Swivel bracket assembly
<b>Warranty</b>	Two year from factory shipping date Extended warranty available.

## ORDERING INFORMATION

<b>SS4-A2</b>	Electro-Optical Detector
<b>SS4-AS</b>	Optimized for Non-Hydrocarbon Fires
<b>SM4</b>	Stainless Steel Swivel Mount
<b>FT-2145</b>	Explosion-proof Test Lamp
<b>MA420-4</b>	4-20 mA current Module
<b>CM1-A</b>	Wall-mount Controller
<b>MB-3</b>	ModBus Module

Dimensions are in inches  
This specification is subject to change without notice.

**FIRE SENTRY CORPORATION**

593 Apollo Street, Brea, California 92821  
Tel: (714) 671-1100 Fax: (714) 671-5821

Email: [sales@firesentry.com](mailto:sales@firesentry.com)  
Web page: [firesentry.com](http://firesentry.com)

Copyright 2005, All Rights Reserved  
DS-101

Figure 78: Fire Sentry Corporation Flame Detector Specifications



## IR-TCM 384 HiRes IR camera module

Thermal images, 384 x 288 pixel resolution



### First commercially available camera module for 384 x 288 resolution in real-time

Whether visualizing or measuring heat distribution charts, the new uncooled OEM IR camera module IR-TCM 384 outputs impressive infrared images of 384 x 288 pixel resolution with a sharpness and distinctness so far unknown at commercial level. What's more, it does so in real-time! If configured with an optional hardware extension for resolution enhancement, it can even produce close to photo-realistic IR pictures with 768 x 576 pixel resolution.

### Excellent for machine vision and security applications

With its image format, the module with uncooled microbolometer provides a long-missed imaging quality for image recognition and machine vision purposes, which is preferred in such applications. This can also work out very helpfully in security environments given that the module's

high image resolution capability can handle large enough data volumes for wide-angle objective lenses to monitor great visual fields.

Equipped with such standard interfaces as FireWire, S-Video and RS232, the infrared camera module can easily be integrated into a variety of applications in little time.

### Applications:

- Machine vision
- Property monitoring
- Aerial inspection
- Infrared microscopy
- Security engineering
- Person detection
- Fire detection
- Vehicle detection
- Thermal inspection systems
- Military engineering

Excellence through light: Sensors



# IR-TCM 384 HiRes IR camera module

Thermal images, 384 x 288 pixel resolution

## Technical Specifications

IR-TCM 384 HiRes	
Detector type	Uncooled microbolometer (Focal Plane Array, no export limitations within OECD countries)
Image format	384 x 288 (768 x 576 pixel in RE Mode)
Spectral range	7.5 ... 14 $\mu$ m
Range for temperature visualization <sup>1)</sup>	-40 ... +300 °C
Temperature resolution	NETD < 80 mK
Dynamic range	16 bit
Cooling	not required
Image rate	50 Hz (PAL) or 60 Hz (NTSC)
Interfaces	IEEE-1394 (Firewire®), S-Video, RS 232
Power supply	7.2 ... 24 V
Operating temperature	-15 ... +50 °C
Storing temperature	-40 ... +70 °C
Humidity	Relative humidity 10% to 95%, non-condensing
Shock	Operational: 25G, IEC 68-2-29
Vibration	Operational: 2G, IEC 68-2-6
Dimensions	153 mm x 91 mm x 111 mm
Weight (without lens)	1050 g
Options	<ul style="list-style-type: none"> <li>+ opto-mechanical Resolution Enhancement for 768 x 576 pixel image resolution</li> <li>+ Further interface options (e.g. Gigabit-Ethernet)</li> <li>+ Implementable image processing functionality (e.g. image filtering, zoom, auto-image, hot- &amp; cold-spot-detection, measurement spots, measurement value correction, etc.)</li> <li>+ Remote control and image capturing software</li> <li>+ Image analysis software</li> <li>+ Lenses:               <ul style="list-style-type: none"> <li>- Wide angle lens: 1.0/12.5mm (FOV 57° x 44°)</li> <li>- Standard lens: 1.0/25mm (FOV 30° x 23°)</li> <li>- Telephoto lens 1: 1.0/50mm (FOV 15° x 12°)</li> <li>- Telephoto lens 2: 1.0/130mm (FOV 5.9° x 4.4°)</li> </ul> </li> </ul>
<sup>1)</sup> Overall range available for visualization. Two discrete sensitivity levels are used (1: -40 °C ... +120 °C, 2: 0 °C ... +300 °C).	

Product design and specification are subject to continuous ongoing development. We reserve the right to make changes in the interest of technical progress.



JENOPTIK Laser, Optik, Systeme GmbH  
Business Unit Sensor Systems  
Goeschwitzer Str. 25, 07745 Jena, Germany  
Phone +49 3641 65-3942 Fax +49 3641 65-3494  
e-mail: [infraredtechnology@jenoptik.com](mailto:infraredtechnology@jenoptik.com)  
Internet: [www.infraredtechnology.com](http://www.infraredtechnology.com)



Jenoptik-IR  
(561) 881-8115  
West Palm Beach, FL 33407

[www.jenoptik-ir.com](http://www.jenoptik-ir.com)  
[sales@jenoptik-ir.com](mailto:sales@jenoptik-ir.com)

division of Coastal Optical Systems, Inc.

014801-TC-M384-95-14-0207-40

Figure 79: Jenoptik Infrared Camera Specifications

# Panasonic

ideas for life

Network Camera  
 Indoor use **BB-HCM715**  
 Outdoor use **BB-HCM735**  
\*AC adaptor is sold separately.

Viewnetcam.com  
Access www.viewnetcam.com for registration information.

UPnP

PoE Ready

RoHS

\* This logo mark is issued by the IEC (International Electrotechnical Commission), an IEC's protection group established mainly by the IEC Forum.

## See from Anywhere with a Variety of Monitoring Environments



BB-HCM735

**See There**  
 When You Can't Be There™



passageway



Garage



Stores



Entrances

**Zero Distance Management**

Zero Distance Management is a new business style made possible by Panasonic network cameras. It allows safe, smooth, economical business management that is totally free from conventional distance and time limitations.

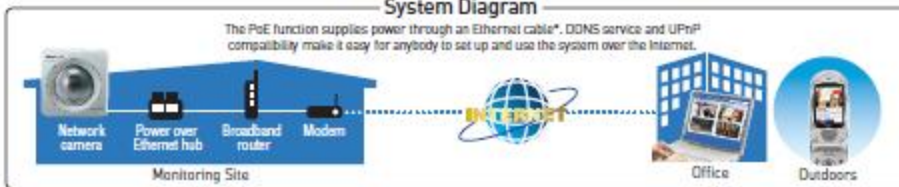

### System Diagram

The PoE function supplies power through an Ethernet cable\*. DDNS service and UPnP compatibility make it easy for anybody to set up and use the system over the Internet.



\*An optional AC adaptor can also be used.

# Achieving Zero Distance Management with a Variety of Functions





### Capture

#### Megapixel Cameras

**Mega pixel and higher image quality**  
Resolution has been improved to 1280 x 960 pixels, enabling rendering of finer detail. VGA [Video Graphics Array] quality has also been improved.

Megapixel image quality comparison of new and existing models



Existing model: Displays crisper image

New model: BB-HCM735 (VGA)

#### 2x2 Pixel Binning

2 x 2 pixel binning treats four adjacent pixels as one virtual pixel, thereby increasing camera sensitivity, and improving visibility in low light conditions

#### 4-pixel summation function

This function cannot be used with 1280 x 960 display resolution. The ON/OFF setting of this function is fixed and cannot be switched over automatically.

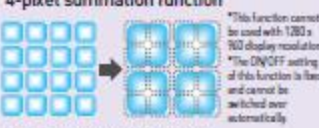

#### Image quality comparison



BB-HCM735 (with 4-pixel summation function ON) vs BB-HCM735 (standard mode)

### Control

#### EX Zoom

Although not equipped with optical zoom, these models have an EX Zoom [EX is supposed to stand for "excellence"] function. This allows high image quality during VGA [Video Graphic Array] display with the use of 1280 x 960 pixel image.

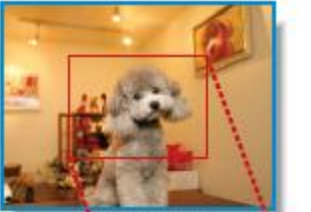

1280 x 960 pixel display

This allows high image quality during VGA [Video Graphic Array] display.



VGA (640 x 480 pixel) display

EX Zoom (x2)

### Installation

#### Enhanced waterproof performance

BB-HCM735 can be directly installed onto any outdoor walls. Wider choice of outdoor installation location (formerly limited to space under the eaves, etc.) expands its scope of application, catering better to users' needs.

\* When the camera is installed according to the instructions provided in the included documentation, and the camera has been properly waterproofed.



Network camera

#### Connector cover and cable guard provide protection against wind and rain to ensure uninterrupted signal transfer.



Connector cover  
Cable guard

### Connect

#### Data transmission / H.264 adopted

The adoption of H.264/ACV has enabled reduction of data volume by more than 30% compared to MPEG-4 when transmitting data of the same image quality.

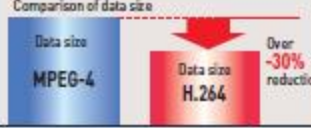

Comparison of data size

Data size MPEG-4 vs Data size H.264 (Over ~30% reduction)

### Part Names

#### Front View



BB-HCM715 BB-HCM735

Sunshade  
Lens cover  
Lens  
Indicator  
Microphone

#### Rear View

Factory default reset button



SD Memory Card slot  
Restart button  
Function button/indicator  
LAN port  
Mic terminal  
Audio out terminal  
Video out terminal  
Stand mounting hole  
Serial number and MAC address label

Specifications [BB-HCM715/BB-HCM735]		
<b>System</b>	Camera	General
Image Compression	JPEG (of which, MPEG-4, H.264)	Operating Temperature
Image Resolution	1280 x 960, 640 x 480, 320 x 240 (optional), 192 x 144 <sup>1)</sup>	BB-HCM715 Operation: -10°C (-14°F) to +50°C (+122°F) Storage: -40°C (-40°F) to +100°C (+212°F)
Image Quality (AVC on)	JPEG (lower clarity, standard, best motion)	BB-HCM735 Operation: -20°C (-4°F) to +50°C (+122°F) Storage: -35°C (-31°F) to +45°C (+113°F)
Picture Ratio <sup>2)</sup>	Max. 30 frames/second (1/30 sec) video (4:3, 16:9, 17:9)	Operating Humidity
Security	User ID/password/SSL	BB-HCM715 Operation: 20% - 80% (no condensation) Storage: 20% - 90% (no condensation)
Supported Protocols	On: (Protocol list) No: (Protocol list)	BB-HCM735 Operation: 20% - 90% (no condensation) Storage: 20% - 90% (no condensation)
User Access Limit	No. 20 (maximum access No. 2 accessible during HTTP) (max. 100 connections) (max. 100 connections/100 connections)	Compression (1:2, 4:1, 8:1)
Buffered Image	About 120 frames (20 x 200, standard image quality with one step display (when SD memory card is not inserted))	Weight (Only the Unit)
Image Transfer Method	SMTP <sup>3)</sup> , FTP, HTTP	BB-HCM715: 200 g (7.05 oz.) BB-HCM735: 210 g (7.5 oz.)
Image Notify (Email Notify)	Alarm, Error, Motion detection	Power Consumption
Zoom	In zoom (2x, 4x zoom, 2x digital zoom)	When Using an Optional AC Adaptor (Model No. BB-HCM700) About 2.3 W (7.5 W during pan/tilt scan)
Viewing Angle	Horizontal: 60° (max. 130°), vertical: 51° (max. 130°) Pan: -50° up to +50°, Tilt: -45° up to +45°	When Using an Optional AC Adaptor (Model No. BB-HCM700) About 2.3 W (7.5 W during pan/tilt scan)
Max. Viewing Speed	Pan: max. 80°/sec, tilt: max. 80°/sec	When Using POC (Power over Coax) (Model No. BB-HCM700) Input: 100-240 V AC, 50/60 Hz Output: 12 V DC, 750 mA Input: 100-240 V AC, 50/60 Hz Output: 12 V DC, 750 mA P.O.C. (PoE standard) (IEEE802.3af-2003)
	Camera type	1) Model V224
	Lens focal/Photo	2) Power line (e.g. telephone line) (during installation)
	Aperture/F-number	3) When using a network cable (during installation)
	White balance	4) When using a network cable (during installation)
	IR sensor	5) When using a network cable (during installation)
	Exposure	6) When using a network cable (during installation)
	Audio	7) When using a network cable (during installation)
	Audio Communication	8) When using a network cable (during installation)
	Audio Input/Output	9) When using a network cable (during installation)
	Audio Recording Method	10) When using a network cable (during installation)
	Audio Bandwidth	11) When using a network cable (during installation)
	Audio Input	12) When using a network cable (during installation)
	Audio Output	13) When using a network cable (during installation)
	Audio Output	14) When using a network cable (during installation)
	Network Interface	15) When using a network cable (during installation)
	Network Standard	16) When using a network cable (during installation)
	Network LAN Standard	17) When using a network cable (during installation)
	VLAN Support	18) When using a network cable (during installation)
	Audio Output <sup>4)</sup>	19) When using a network cable (during installation)
	Control Microphone Input	20) When using a network cable (during installation)
	SD Memory Card Slot	21) When using a network cable (during installation)

Figure 80: Panasonic Optical Camera Specifications

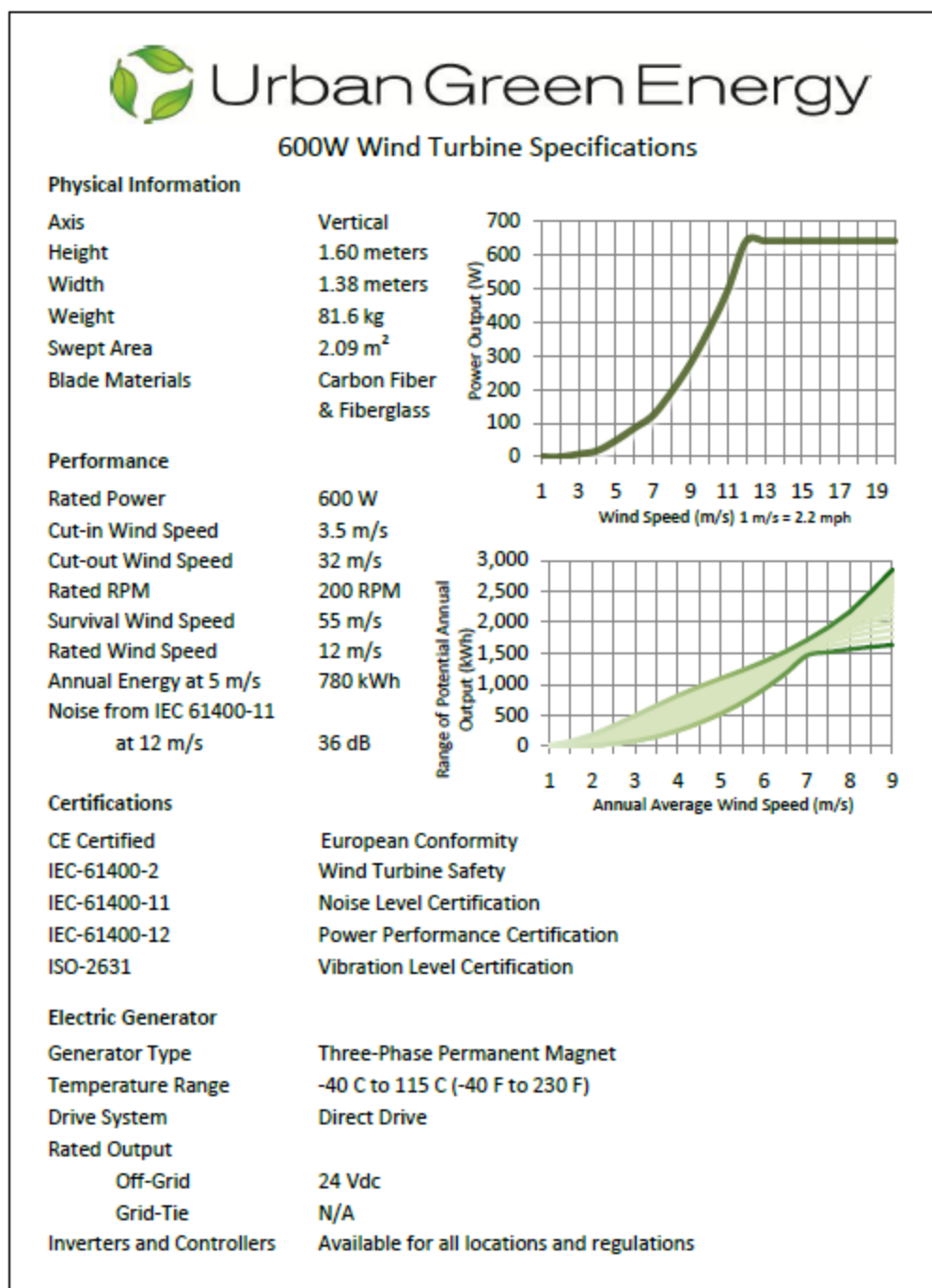

**Figure 81: Specifications for 600 watt VAWT**

# SPECIFICATIONS

Applicable Battery .....	Low maintenance sealed lead acid battery
Battery Charging Methodology .....	Pulse Width Modulation (PWM)
Voltage Configurations .....	24 V or 48 V DC
LED Indicator .....	Battery status, wind generator status, diversion load status
Battery Over-charging Protection Voltage .....	28.2-29 V or 56.4-58 V
Charging Loop Voltage Drop .....	≤5%
No-load Loss .....	<1%
Diversion Load Rated Power .....	2 Ohm
Specified Temperature Range .....	-40 °C to +50 °C (40 °F to 122 °F)
Dimensions .....	Controller: 240X182X150 mm (9.45X7.16X5.9 in)
	Diversion Load Box: 412X172X150 mm (16.22X6.77X5.9 in)
Weight .....	Controller: 3.2 kg (7 lb) Diversion Load: 3 kg (6.6 lb)

**Figure 82: Specifications for Off-Grid Controller for Alternative Energy System**

# DRAWINGS

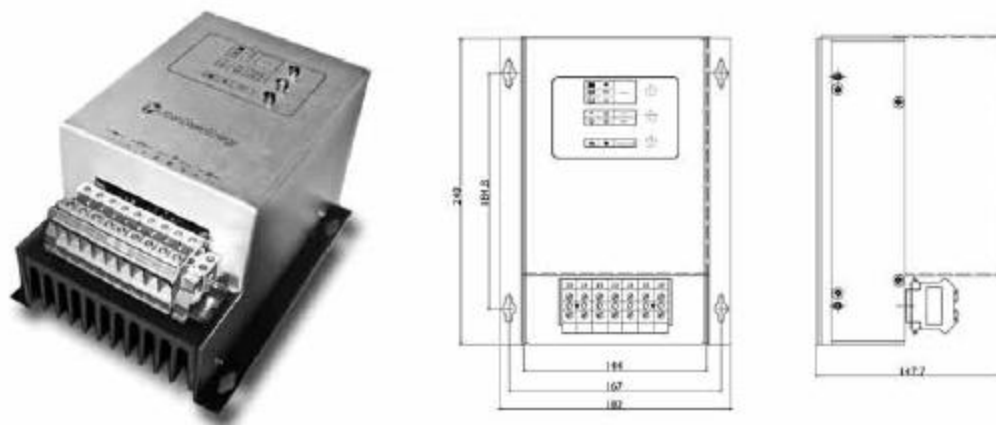

Fig. 1: UGE-600-OGC dimensions (all units in mm)

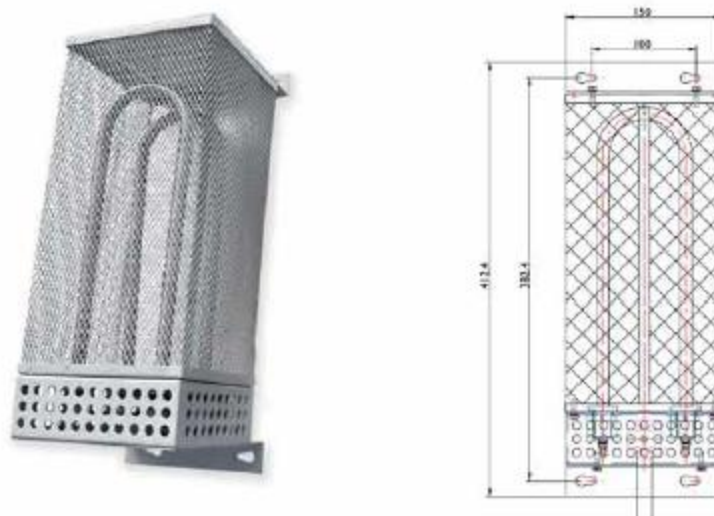

Fig. 2: Controller Diversion Load dimensions

# DRAWINGS

Use the following charts/diagrams to identify the functions of the controller components.

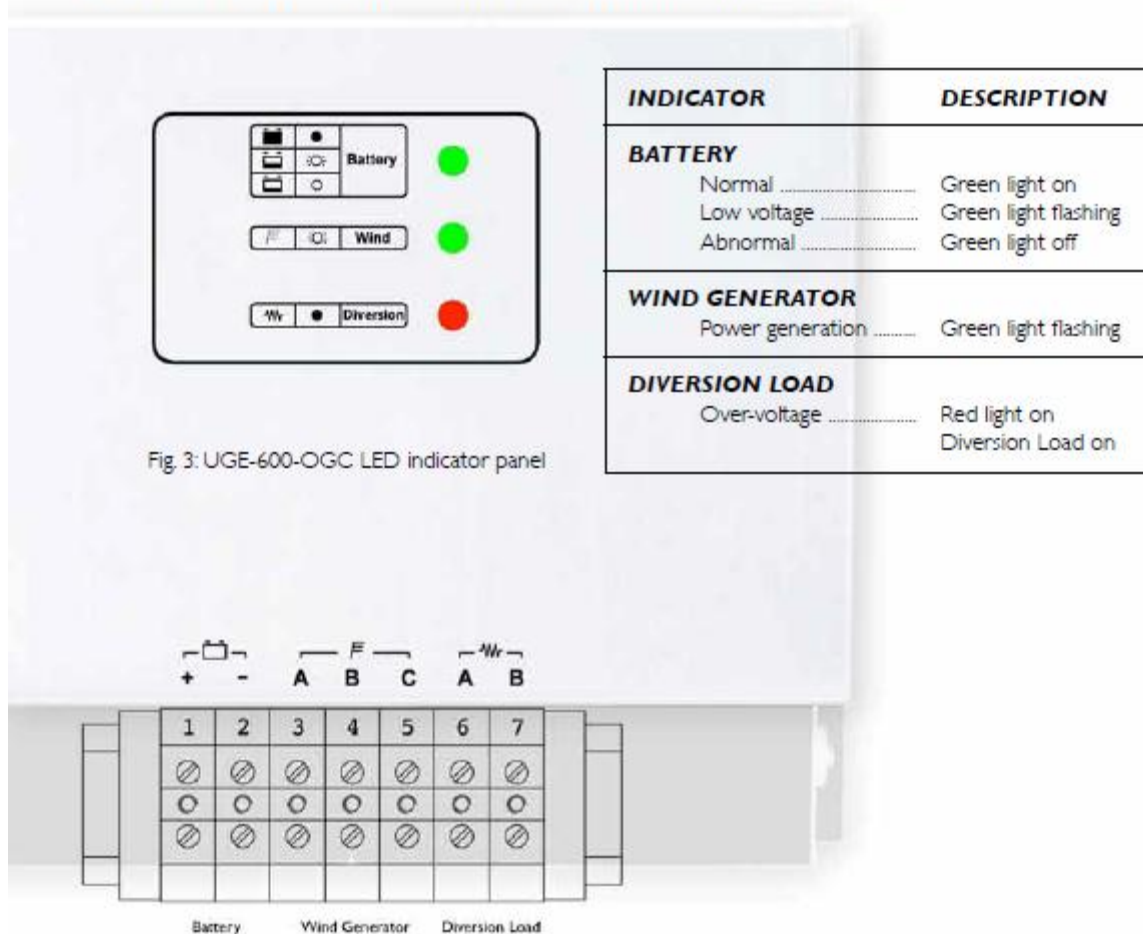

Fig. 3: UGE-600-OGC LED indicator panel

Fig. 4: UGE-600-OGC terminal definition

**Figure 83: Drawings for Off-Grid Controller for Alternative Energy System**



**samlexamerica** 150W

**DC-AC Inverter**  
⚡ **Pure Sine Wave**

<b>Model</b>	SA-150-112
	12 VDC-110 VAC
	SA-150-124
	24 VDC-110 VAC

**Design Features**

- Optional remote power ON / OFF capability
- Isolated Input and output
- Thermal controlled cooling fan
- Advanced microprocessor design
- Input polarity reverse / under voltage / over voltage protections
- Output short circuit / overload / over temperature protections
- Capable of driving highly reactive and capacitive loads
- Tri-color indicators display input, output level & failure status
- True sine wave output (THD 6% Typ.)

**UL** **FC** **2 YEAR WARRANTY**

	MODEL No.	SA-150-112	SA-150-124
<b>OUTPUT</b>	<b>AC VOLTAGE</b>	12 VDC - 110 VAC	24 VDC - 110 VAC
	<b>CONTINUOUS OUTPUT POWER</b>	150 W	150 W
	<b>PEAK OUTPUT POWER</b>	200 W	200 W
	<b>WAVEFORM</b>	True sine wave (THD < 6%)	True sine wave (THD < 6%)
	<b>FREQUENCY</b>	60Hz	60Hz
	<b>AC REGULATION</b>	± 5%	± 5%
	<b>POWER FACTOR ALLOWED</b>	COSq -90° ~ COSq +90°	COSq -90° ~ COSq +90°
	<b>STANDARD RECEPTACLES</b>	NEMA5-15R / GFCI	NEMA5-15R / GFCI
	<b>LED INDICATOR</b>	Input voltage level, output load level and fault status	
	<b>INPUT</b>	<b>NO LOAD CURRENT DRAW</b>	0.20A
<b>DC VOLTAGE</b>		12 VDC	24 VDC
<b>VOLTAGE RANGE</b>		10.5 ~ 15.0 VDC	21.0 ~ 30.0 VDC
<b>EFFICIENCY (Typ.)</b>		87.0%	88.0%
<b>FUSE</b>		25A x 1	15A x 1
<b>REMOTE CONTROL</b>		By external switch	By external switch
<b>BATTERY LOW SHUTDOWN</b>		10 ± 0.5V	20 ± 1.0V
<b>PROTECTION</b>	<b>OVER LOAD</b>	Shut off output voltage, re-power on to recover	
	<b>OVER VOLTAGE</b>	15 ~ 16 VDC / 30 ~ 32 VDC	
	<b>OVER TEMPERATURE</b>	Shut off output voltage, recovers automatically after temperature goes down	
	<b>OUTPUT SHORT</b>	Shut off output voltage, re-power on to recover	
<b>ENVIRONMENT</b>	<b>BATTERY POLARITY REVERSE</b>	By fuse open	By fuse open
	<b>WORKING TEMPERATURE</b>	0 ~ +40°C	
	<b>WORKING HUMIDITY</b>	20% ~ 90% RH non-condensing	
	<b>STORAGE TEMPERATURE &amp; HUMIDITY</b>	-30°C ~ +70°C / -22°F ~ +158°F / 10 ~ 95%	
<b>SAFETY &amp; EMC</b>	<b>SAFETY STANDARDS</b>	UL458 (models with GFC receptacles)	UL458 (models with GFCI receptacles)
	<b>ISOLATION RESISTANCE</b>	I/P ~ O/P: 100M Ohms / 500 VDC	I/P ~ O/P: 100M Ohms / 500 VDC
	<b>EMI CONDUCTION &amp; RADIATION</b>	Compliance to FCC class B	
	<b>EMS IMMUNITY</b>	LVD	
	<b>e-MARK</b>	---	
<b>DIMENSIONS/WEIGHT</b>	<b>INCHES</b>	7.9 x 5.2 x 2.8 (L x W x H)	7.9 x 5.2 x 2.8 (L x W x H)
	<b>MILLIMETERS</b>	200 x 132 x 72 (L x W x H)	200 x 132 x 72 (L x W x H)
	<b>POUNDS</b>	5.6; 6 sets / 41.9 / CARTON	5.6; 6 sets / 41.9 / CARTON
	<b>KILOGRAMS</b>	2.7; 6 sets / 19 / CARTON	2.7; 6 sets / 19 / CARTON
<b>OTHERS</b>	<b>COOLING</b>	Thermostatically controlled cooling fan	
	<b>APPLICATION</b>	Home and Office appliances, Power tools and Portable equipments, Vehicle, Yacht and Solar power systems ...etc.	

NOTE: Specifications are subject to change without notice

To view a full selection of Samlex products visit our website at [www.samlexamerica.com](http://www.samlexamerica.com) or contact us: 1(800) 561-5885 or sales@samlexamerica.com

**Figure 84: Specifications for 24 VDC-110 VAC Inverter**





## TRISTAR MPPT™

### SOLAR CONTROLLER WITH MAXIMUM POWER POINT TRACKING

Morningstar's *TriStar MPPT* solar controller with *TrakStar Technology™* is an advanced maximum power point tracking (MPPT) battery charger for off-grid photovoltaic (PV) systems up to 3kW. The controller provides the industry's highest peak efficiency of 99% and significantly less power loss compared to other MPPT controllers.

The *TriStar MPPT* features a smart tracking algorithm that maximizes the energy harvest from the PV by rapidly finding the solar array peak power point with extremely fast sweeping of the entire I-V curve. This product is the first PV controller to include on-board Ethernet for a fully web-enabled interface and includes up to 200 days of data logging.



Product shown with optional meter

#### Key Features and Benefits

##### ■ Maximizes Energy Harvest

Our *TriStar MPPT Technology* features:

- Better peak power point tracking than other MPPT controllers
- Very fast sweeping of the entire I-V curve
- Recognition of multiple power points during shading or mixed PV arrays
- Excellent performance at sunrise and low solar insolation levels

##### ■ Extremely High Reliability

- Robust thermal design and no cooling fans
- Parallel circuit design provides less stress and longer life for electronic components
- No mechanical relays
- Extensive electronic protections including PV short circuit protection
- Epoxy encapsulated inductors and conformally coated printed circuit boards

##### ■ Very High Efficiency

- Peak efficiency of 99%
- Proprietary tracking algorithm minimizes power losses
- Low self-consumption
- Continuous operation at full power to 45°C without need to de-rate
- Selected electronic devices with higher ratings to minimize losses from heating

##### ■ Extensive Networking and Communications Capabilities

Enables system monitoring, data logging and adjustability. Uses open standard MODBUS™ protocol and Morningstar's MS View software.

- Meterbus: communications between compatible Morningstar products
- Serial RS-232: connection to a personal computer
- EIA-485: communications between multiple devices on a bus
- Ethernet: fully web-enabled interface to a local network or internet; view from a web browser or send email/text messages.

##### ■ Metering and Data Logging

- Optional *TriStar* meter and remote meter provides detailed operating data, alarms and faults
- Three LED's display system status
- Up to 200 days of data logging via meters or communications ports

System Status:

53.60V	28C	54.2A
2867W		MPPT

Data Logging:

Today	Batt	Day: -1	Batt
	46.4 Vmin		47.2 Vmin
Today	Solar	Day: -1	Solar
	58.9 Amax		56.8 Amax
Today	Solar	Day: -1	Solar
	107.2 Vmax		105.5 Vmax

# TRISTAR MPPT™ SOLAR CONTROLLER



## TECHNICAL SPECIFICATIONS

### Electrical

	TS-MPPT-45	TS-MPPT-60
• Maximum Battery Current	45 amps	60 amps
• Nominal Maximum Solar Input		
12 Volt	600 Watts	800 Watts
24 Volt	1200 Watts	1600 Watts
48 Volt	2400 Watts	3200 Watts

### TS-MPPT-45 and TS-MPPT-60

• Peak Efficiency	99%
• Nominal System Voltage	12, 24, 36 or 48 volts DC
• Max. Solar Open Circuit Voltage	150 volts DC
• Battery Operating Voltage Range	8-72 volts DC
• Maximum Self-consumption	2.7 Watts
• Transient Surge Protection	4500 Watts/port

### Electronic Protections

- Solar: Overload, Short Circuit, High Voltage
- Battery: High Voltage
- High Temperature
- Lightning and Transient Surges
- Reverse Current at Night

### Battery Charging

• Charging algorithm	4-stage
• Charging stages	Bulk, Absorption, Float, Equalize
• Temperature Compensation	
Coefficient	-5mV/°C/cell (25° ref)
Range	-30°C to +80°C
Set points	Absorption, Float, Equalize, HVD

Note: Remote Temperature Sensor is included.

### Mechanical

• Dimensions	29.1 x 13.0 x 14.2 cm 11.4 x 5.1 x 5.6 inch
• Weight	4.2 kg / 9.2 lbs.
• Max. Wire Size	35 mm <sup>2</sup> / 2 AWG
• Conduit knockouts	M20; ½, 1, 1 ¼ inch
• Enclosure	Type 1 (indoor and vented) IP20

### Environmental

- Ambient Temperature -40°C to +45°C
- Storage Temperature -55°C to +100°C
- Humidity 100% non-condensing
- Tropicalization Epoxy encapsulation  
Conformal coating  
Marine rated terminals



### Communication Ports

	TS-MPPT-45	TS-MPPT-60
• MeterBus	Yes	Yes
• RS-232	Yes	Yes
• EIA-485	No	Yes
• Ethernet	No	Yes

### Options

- TriStar Meter-2 (TS-M-2)
- TriStar Remote Meter-2 (TS-RM-2)
- Meter Hub (HUB-1)
- Relay Driver (RD-1)

### Certifications

- CE Compliant
- ETL Listed (UL1741)
- cETL (CSA C22.2 No. 107.1-01)
- FCC Class B Part 15 Compliant
- Complies with (NEC) U.S. National Electric Code
- RoHS Compliant
- Manufactured in a certified ISO 9001 facility

**WARRANTY:** Five year warranty period. Contact Morningstar or your authorized distributor for complete terms.

**AUTHORIZED MORNINGSTAR DISTRIBUTOR:**

**MORNINGSTAR**  
corporation

8 Pheasant Run  
Newtown, PA 18940 USA  
Tel: +1 215-321-4457 Fax: +1 215-321-4458  
E-mail: [info@morningstarcorp.com](mailto:info@morningstarcorp.com)  
Website: [www.morningstarcorp.com](http://www.morningstarcorp.com)



© 2010 MORNINGSTAR CORPORATION PRINTED IN USA 2246-03-970

Figure 85: Specifications for Morningstar Solar Controller

Technical Data | Photovoltaic modules



## Conergy P 230PA

The Conergy P 230PA offers high output levels at an attractive price/performance ratio. Equipped with 60 efficient, polycrystalline cells, they have proven their value in practical applications and years of operation. They are characterized by high yields and a long service life. Conergy P production is certified to ISO 9001 international quality standards and Conergy continually monitors the production process to insure product quality. These high-efficiency modules are powerful and versatile enough for any application from residential through utility scale.

Solar modules in the Conergy P-series are also available with monocrystalline and polycrystalline cells in other power classes and different module dimensions.

### Features:

- | Attractive price/performance ratio
- | High-efficiency 3-busbar cells
- | Certified to UL1703, IEC/EN61215, 61730
- | High-performance,  $\pm 3\%$  power tolerance
- | 5-year product warranty



Technical Data | Photovoltaic modules

# Conergy P 230PA

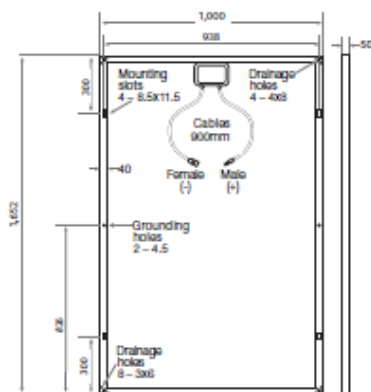

All dimensions in mm

<b>Module dimensions</b>	
(L x W x H)	1652 x 1000 x 50 mm/65.0 x 39.4 x 2.0 In
Cell dimensions	156 x 156 mm/6.14 x 6.14 in
Number of cells	60
Module weight	22 kg/48.5 lb
Static wind/snow load	5400PA/113psf
Glass	Tempered, A/R coating
Junction box	IP65 Class
Cable	900 mm/35.4 In PV Wire, 4 mm <sup>2</sup>
Connector	Amphenol H4 (MC4 compatible)
<b>Certifications</b>	
Operating certifications	cULus, IEC 61215 Ed.2
Fire safety classification	Class C
<b>Warranty</b>	
Material and workmanship warranty	5 years
Power warranty 1	90%/12 years
Power warranty 2	80%/25 years



Conergy P 230PA	
Rated power ( $P_{max}$ ) <sup>1</sup>	230W
Power tolerance	±3%
Module efficiency	13.90%
Maximum power voltage ( $V_{mp}$ )	30.00V
Maximum power current ( $I_{mp}$ )	7.67A
Open circuit voltage ( $V_{oc}$ )	36.8V
Short circuit current ( $I_{sc}$ )	8.34A
Nominal Operating Cell Temperature (NOCT)	45.3°C/113.5°F
Temperature coefficient ( $P_{max}$ )	-0.45%/°C
Temperature coefficient ( $V_{oc}$ )	-0.32%/°C
Temperature coefficient ( $I_{sc}$ )	+0.04%/°C
Operating temperature range	-40°C - +85°C / -40°F - +136°F
Maximum system voltage	600V (UL)/1000V (IEC)
Maximum Series Fuse Rating	15A

<sup>1</sup> At Standard Test Conditions (STC): 1000W/m<sup>2</sup>, 25°C, AM 1.5 spectral density  
<sup>2</sup> Available at additional cost

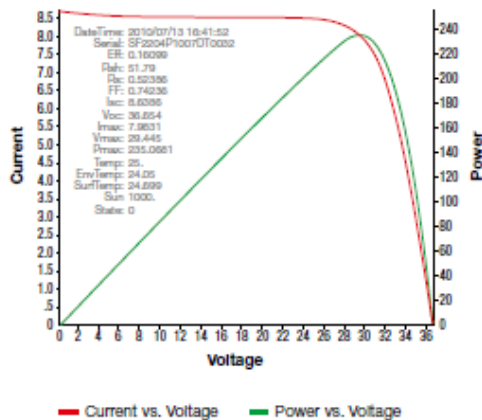

Subject to technical modifications without notice 201903 Conergy  
 ConergyP\_230PA-TD-ENG-0111

www.conergy.com



Figure 86: Specifications for Conergy P 230PA

## CHAPTER 10 REFERENCES

Arata, Michael J. *Perimeter Security*. New York: McGraw-Hill, 2006. Print.

Becker, Fred J. "History of Covered Bridges." Web. 24 May 2011.  
<<http://www.fredbecker.org/News Letter/HistoryCoveredBr.htm>>.

CBC News. "CBC News - New Brunswick - N.B. Covered Bridge Destroyed by Fire." *CBC.ca*. 15 Oct. 2009. Web. 18 Feb. 2011.  
<<http://www.cbc.ca/canada/newbrunswick/story/2009/10/15/nb-covered-bridge-fire.html>>.

Conrath, Edward J. *Structural Design for Physical Security: State of the Practice*. Reston, VA: SEI, 1999. Print.

Durfee, Robert H. "Vermont's Covered Bridges, Vermont, Tours, History, Trusses." *Vermont Covered Bridge Society, Covered Bridges, Covered Bridge News*. 1 Aug. 2003. Web. 4 May 2010. <<http://www.vermontbridges.com/fire paper.htm>>.

Fennelly, Lawrence J. *Effective Physical Security*. 2nd ed. Boston, Mass: Butterworth-Heinemann, 1997. Print.

Hampson, Rick. "Fire-starting Vandals Attack Beloved Covered Bridges - USATODAY.com." *News, Travel, Weather, Entertainment, Sports, Technology, U.S. & World - USATODAY.com*. 14 June 2007. Web. 18 Feb. 2011.  
<[http://www.usatoday.com/news/nation/2007-06-14-covered-bridges\\_N.htm](http://www.usatoday.com/news/nation/2007-06-14-covered-bridges_N.htm)>.

Hering, Achim. "The Proof Is in the Fire." *Chemical Innovation* 31.5 (2001): 17-21. Print.

Matias, Everett. "National Historic Covered Bridge Preservation Program - Programs - Integrated - Bridge - FHWA." *Federal Highway Administration: Home*. 21 June 2009. Web. 18 Feb. 2011. <<http://www.fhwa.dot.gov/bridge/covered.cfm>>.

Murphy, Kara. "Bridge Arson Part of Crime Spree." *GoErie.com*. 19 Dec. 2008. Web. 18 Feb. 2011.  
<<http://www.goerie.com/apps/pbcs.dll/article?AID=/20081219/NEWS02/312199926/-1/NEWS02>>.

National Fire Data Center. "Intentionally Set Outdoor Fires." *Topical Fire Report Series* 9.6 (2009): 1-8. Print.

Overington, Caroline. "Burn, Hollywood Burn - Bridges of Madison County Threatened by Arson " *Sydney Morning Herald - Business & World News Australia*. 1 Dec. 2003. Web. 18 Feb. 2011.  
<<http://www.smh.com.au/articles/2003/11/30/1070127272751.html?from=storyrhs>>.

Phares, Brent M. *Remote Monitoring of Historic Covered Timber Bridges for the Prevention of Arson and Vandalism*. Madison, WI: U.S. Dept. of Agriculture, Forest Service, Forest Products Laboratory, 2006. Print.

Pierce, Phillip C. *Covered Bridge Manual*. McLean, VA: U.S. Department of Transportation, Federal Highway Administration, Research, Development, and Technology, Turner-Fairbank Highway Research Center, 2005. Print.

Rinehart, Jack. "Convicted Arsonist Held After Fire Destroys Covered Bridge - Indiana News Story - WRTV Indianapolis." *Indianapolis News, Indianapolis, Indiana News, Weather, and Sports - WRTV Indianapolis' Channel 6*. 28 Apr. 2005. Web. 18 Feb. 2011. <<http://www.theindychannel.com/news/4427578/detail.html>>.

"Solar & Wind Energy Calculations: The (very) Basics." *Www.solar-estimate.org*. Energy Matters. Web. 21 June 2011.

The Blue Ribbon Panel on Bridge and Tunnel Security. *Recommendations for Bridge and Tunnel Security*. Washington, D.C.: U.S. Dept. of Transportation, Federal Highway Administration, 2003. Print.

Tyska, Louis A., and Lawrence J. Fennelly. *Physical Security: 150 Things You Should Know*. Boston: Butterworth-Heinemann, 2000. Print.